



Australasian Explosives Industry Safety Group Inc.

Code of Practice

ELEVATED TEMPERATURE AND

REACTIVE GROUND

Edition 5

April 2020



Australasian Explosives Industry Safety Group Inc.

CODE OF PRACTICE

ELEVATED TEMPERATURE AND REACTIVE GROUND

Edition 5

April 2020

About AEISG

The Australasian Explosives Industry Safety Group (AEISG) is an incorporated association of Australasian explosives manufacturers and suppliers originally formed in 1994.

Since then, AEISG membership has grown substantially to include most of the Australasian explosives industry. A full list of all current member organisations can be found on the AEISG website, www.aeisc.org.au

The goal of AEISG is to continuously improve the level of safety and security throughout our industry in the manufacture, transport, storage, handling and use of explosives and related materials.

One of the strategies adopted by AEISG in this regard is to identify areas where improved and consistent standards of operational safety and security need to be applied, and then develop appropriate codes which reflect industry best practice in these areas.

AEISG codes of practice are adopted by members for the benefit of their employees, their customers and the general community. In the interest of promoting safety and security, the codes are freely available on the AEISG website.

To keep abreast of technological advancements, industry progress and regulatory changes, AEISG codes of practice are subject to regular review and updated through the issue of amendments or revised editions as necessary. It is important that users ensure they are in possession of the latest edition and aware of any amendments. References to superseded versions should be updated accordingly.

Contact Details: info@aeisc.org.au

Copyright

© AEISG Inc. 2020

This document is subject to copyright. No parts of it should be reproduced without the written consent of copyright owner.

ISBN 978-1-921308-27-7

Disclaimer

AEISG Inc has taken reasonable care in the preparation of the information contained in this code and believes it to be accurate. However, AEISG Inc does not guarantee or warrant the accuracy, completeness or currency of the information contained in this code. As AEISG Inc cannot anticipate or control the conditions under which this information may be used, each user should review the information in the specific context of the intended application. Under no circumstances will AEISG Inc or any of its members be responsible for, or accept liability for, any loss, expense, cost or damage of any nature resulting from the use of or reliance upon the information contained in this code. To the fullest extent permitted by law, AEISG Inc disclaims all warranties, whether express, implied, statutory or otherwise, in relation to the information contained in this code.

PREAMBLE

The use of explosives to break rock is an intrinsically hazardous process. These hazards have been studied over the years and modern mining methods have evolved to minimise the inherent risks of blasting under most conditions.

This Code has been developed to assist the safe use of explosives in situations where a specific additional hazard may exist due to the possible unwanted reaction between an explosive and the rock being blasted. In such situations the unwanted reactions may result in premature detonations with potentially fatal results. The reactions can be caused by rock chemistry or temperature or a combination of both.

The purpose of this Code is to provide a scientific and objective basis for predicting the potential unwanted explosive/rock reaction and to provide practical advice on preventive mechanisms available.

The information is provided in good faith and without warranty.



Contents

PREAMBLE	4
SECTION 1 SCOPE AND DEFINITIONS	8
1.1 SCOPE AND INTERPRETATION OF THE CODE	8
1.2 DEFINITIONS	8
1.3 LIST OF STANDARDS, AND REFERENCES	9
SECTION 2 REGULATORY REQUIREMENTS	11
SECTION 3 BACKGROUND	12
3.1 CASE HISTORIES	12
SECTION 4 RISK ASSESSMENT – INDICATORS OF REACTIVE GROUND	15
SECTION 5 ELEVATED TEMPERATURE BLASTING	16
5.1 PRINCIPLES FOR ELEVATED TEMPERATURE MANAGEMENT	16
5.2 CAUSES OF ELEVATED TEMPERATURE GROUND	16
5.3 RISKS AND HAZARDS OF BLASTING IN ELEVATED TEMPERATURE GROUND	16
5.4 RISK MANAGEMENT THROUGH OPERATING PRACTICES	16
5.4.1 <i>Site Specific Operating Procedures</i>	16
5.4.2 <i>Training</i>	17
5.4.3 <i>Sleep Time</i>	17
5.4.4 <i>Hole Temperature Monitoring</i>	17
5.4.5 <i>Hole Loading Sequence</i>	18
5.4.6 <i>Occupational Health and Safety Considerations</i>	18
5.4.7 <i>Delineation of Zones</i>	18
5.4.8 <i>Spillages</i>	18
5.5 RISK MANAGEMENT THROUGH PHYSICAL SEPARATION	18
5.6 RISK MANAGEMENT THROUGH PRODUCT SELECTION	18
SECTION 6 REACTIVE GROUND BLASTING	19
6.1 PRINCIPLES FOR REACTIVE GROUND MANAGEMENT	19
6.2 CHEMISTRY OF REACTIVE GROUND	19
6.3 RISKS AND HAZARDS – BLASTING IN REACTIVE GROUND	20
6.4 RISK MANAGEMENT THROUGH OPERATING PRACTICES	20
6.4.1 <i>Site Specific Operating Procedures</i>	20
6.4.2 <i>Training</i>	20
6.4.3 <i>Sleep Time</i>	21
6.4.4 <i>Hole Temperature Monitoring</i>	21
6.4.5 <i>Shot Design in Reactive Ground Blasting</i>	21
6.4.6 <i>Hole Loading Sequence</i>	21
6.4.7 <i>Stemming Material</i>	21
6.4.8 <i>Product Spillage</i>	22
6.4.9 <i>Overfilling of Holes</i>	22
6.4.10 <i>Occupational Health and Safety Considerations</i>	22
6.4.11 <i>Ongoing Review of Risk Assessment</i>	22
6.4.12 <i>Delineation of Zones</i>	23



6.4.13	<i>Emergency plans</i>	23
6.5	RISK MANAGEMENT THROUGH PHYSICAL SEPARATION	23
6.5.1	<i>Blast Hole Liners</i>	24
6.5.2	<i>Packaged Explosives</i>	24
6.6	RISK MANAGEMENT THROUGH EXPLOSIVE PRODUCT SELECTION	24
SECTION 7	SAMPLING FOR REACTIVITY TESTING	26
7.1	SAMPLE SELECTION	26
7.2	HANDLING OF SAMPLES.....	26
7.2.1	<i>Sample Size</i>	26
7.2.2	<i>Sample Identification</i>	26
7.2.3	<i>Sample Packaging</i>	26
7.2.4	<i>Sample Timing</i>	27
7.3	SAMPLING FOR INITIAL SCREENING	27
7.4	SAMPLING FOR ONGOING TESTING	27
7.4.1	<i>Existing site – No previous reactivity</i>	27
7.4.2	<i>Existing site – Reactive ground site</i>	28
SECTION 8	REACTIVE GROUND TESTING AND PRODUCT SELECTION	29
8.1	INTRODUCTION	29
8.2	REACTIVITY SCREENING	29
8.2.1	<i>Isothermal Reactive Ground Test</i>	29
8.2.2	<i>Temperature Ramping Test</i>	30
8.3	PRODUCT SELECTION TEST	30
8.3.1	<i>Sleep Time Testing</i>	30
8.3.2	<i>Additional Product Testing</i>	31
8.4	LARGE SCALE TESTING.....	31
8.5	RECOMMENDED TESTING AGENCIES	31
SECTION 9	ELEVATED TEMPERATURE AND REACTIVE GROUND BLASTING	33
9.1	IMPLEMENTATION OF ELEVATED TEMPERATURE AND REACTIVE GROUND PRODUCTS	33
9.2	SHOT DESIGN IN ELEVATED TEMPERATURE AND REACTIVE GROUND BLASTING	33
9.3	DELINEATION BY TEMPERATURE	33
SECTION 10	SELECTION OF ACCESSORIES	35
SECTION 11	PROCEDURES FOR MISFIRES & EXTENDING SLEEP TIME	36
11.1	MISFIRES IN ELEVATED TEMPERATURE GROUND	36
11.2	MISFIRES IN REACTIVE GROUND.....	36
11.3	EXTENDING SLEEP TIME IN HOT AND/OR REACTIVE GROUND.....	37
SECTION 12	MANAGEMENT OF PREMATURE REACTION/DETONATION EVENTS	38
SECTION 13.	ACTIVITY SEQUENCE – MANAGEMENT FLOWCHARTS	39
13.1	IDENTIFICATION AND ANALYSIS OF THE RISK OF REACTIVITY AT GREEN FIELD SITES	39
13.2	IDENTIFICATION AND ANALYSIS FOR THE RISK OF REACTIVITY AT EXISTING SITES	40
SECTION 14	TRAINING	41
APPENDICES		42
APPENDIX 1	TYPICAL REACTIVE GROUND INDICATOR RISK ASSESSMENT CHECKLIST	42



APPENDIX 2	BASIS FOR THE ISOTHERMAL TEST METHOD IN DETERMINING REACTIVE GROUND.....	43
APPENDIX 3	ISOTHERMAL REACTIVE GROUND TEST.....	46
APPENDIX 4	BUCKET TEST FOR REACTIVE GROUND	53
APPENDIX 5	SAMPLE AUDIT GUIDELINES FOR THE INSPECTION OF LABORATORIES	55
APPENDIX 6	GROUND TEMPERATURE TESTING.....	58
APPENDIX 7	AUDIT CHECKLIST FOR ELEVATED TEMPERATURE AND REACTIVE GROUND BLASTING	58



Section 1 Scope and Definitions

1.1 Scope and Interpretation of the Code

The aim of this Code is to enhance the safety of explosive suppliers and their customers when handling explosives and charging in elevated temperature and/or reactive ground conditions.

The Code covers the following:

- Outlines the nature of elevated temperature and reactivity, and the current understanding on the mechanisms of elevated temperature and reactive ground chemistry.
- Summarises the hazards and risks associated with blasting in elevated temperature and/or reactive ground.
- Provides recommended risk assessment methods including sampling and testing for reactivity and measuring elevated temperature conditions at new and existing sites
- Provides guidelines for the risk management of operations at elevated temperature and/or reactive ground sites including blasting methods and systems.
- Provides guidelines for managing misfires and premature detonations in elevated temperature and/or reactive ground.

The customer must establish whether there is elevated temperature and/or reactive ground, as detailed in this Code, on their site. In so doing the customer may request assistance from its explosives supplier to conduct appropriate risk assessments and to make recommendations as to the appropriate risk management procedures for the handling of explosives to ensure the safety and well-being of all personnel working on the site. The responsibility for implementing these procedures will always remain with the customer, and an explosives supplier may withhold supply of product for use in situations where the risk assessments undertaken based on the guidelines of this Code indicate that the risks are unacceptable. The customer has the responsibility of disclosing to its explosives supplier any history or suspected history of elevated temperature and/or reactive ground on the site, and must reveal any changes in geological conditions that may indicate the presence of elevated temperature and/or reactive ground.

Should a customer carry out his own assessment of elevated temperature and/or reactive ground the explosives supplier will always have the right to review this assessment or to carry out their own assessment based on this Code, and decide whether there are appropriate controls in place by the customer to ensure that the supply of explosive products can be made to an acceptable and agreed level of risk. Explosives suppliers have a responsibility to ensure that employees are always offered a safe place of work to carry out their defined duties.

It is the 'duty of care' of explosives suppliers to advise customers of the risks associated with elevated temperature and/or reactive ground and to offer products appropriate to the site application. If the customer chooses to operate contrary to this advice, explosives suppliers reserve the right to withdraw their products and services. If a request is received from a regulator, the explosives supplier will inform the regulator of sites that have elevated temperature and/or reactive ground conditions as assessed by this Code.

1.2 Definitions

"Customer" – the person with direct management responsibility for the design of blasting practices in any blasting situation including the selection of explosive products.

"Elevated temperature" – material that is above 55°C and includes both hot ground and high temperature ground conditions as defined in AS2187.2-2006.



“Elevated temperature products” – explosive products that have been formulated and/or packaged and tested to withstand a nominated higher than ambient temperature for a recommended period of time before they will deteriorate or become unstable and possibly decompose violently or explode.

“High temperature ground” – High temperature blasting is defined as the blasting of material at 100°C or greater [AS 2187.2-2006 – Section 12.7]

“Hot ground” – material shall be defined as hot if its temperature is 55°C or more but less than 100°C [AS 2187.2-2006 – Section 12.6.1]

“Inhibited product” – explosive product that chemically suppresses the reaction between nitrates and sulphides.

“Reactive ground” – ground that undergoes a spontaneous exothermic reaction after it comes into contact with nitrates. The reaction of concern involves the chemical oxidation of sulphides (usually of iron or copper) by nitrates and the liberation of potentially large amounts of heat. The process is unpredictable and can be so violent that it results in premature or unplanned initiation of explosives.

“Reactivity” – this term may be defined in two ways:

- The induction time for the sulphide/nitrate reaction in a constant temperature situation (i.e. a short induction time indicates a higher level of reactivity); or
- The onset temperature for the sulphide/nitrate exotherm in a temperature ramping situation (i.e. a lower onset temperature indicates a higher level of reactivity).

“Shall/should” - For the purpose of this Code ‘shall’ is understood as mandatory and the word ‘should’ is advisory.

“Site Operator” – definition as for “Customer”.

“Sleep time” – the period of time that an explosive is left in a blast hole until it is fired. The time is measured from the time of the beginning of loading until the time of firing.

“Start-up product” – explosive product that is produced in the change-over from manufacturing non-reactive and reactive ground explosive products or precursors.

1.3 List of Standards, and References

In the development of this Code a number of relevant references were consulted and are listed. These references may be useful to the reader in gaining a further understanding of the issues associated with the use of explosives in elevated temperature and/or reactive ground situations.

- AS 2187.2 – 2006 Explosives – Storage and Use. Part 2: Use of Explosives.
- AS/NZ ISO 31000:2009 – Risk Management – Principals and Guidelines.

- P Bellairs, “Explosive Ground Reactivity Indicators And Strategies To Overcome This Phenomena”, International Society Of Explosives Engineers, 1997
- M Littlefair, R Rounsley, F Beach, D Jazzini and G Pugh, “Reactive Ground and Ammonium Nitrate Explosive Interactions”, Proceedings 5th Large Open Pit Conference 2003, p15-21.
- G M Lukaszewski, “The Reaction of ANFO Explosives with Mineral Sulfides”, Proc.Aust.Inst. Min.Met 228, December 1968, p61-70.
- B J Kennedy and N Tyson, “Blasting in Reactive Ground”, Proceedings EXPLO 2001, p55-61.
- Y Miron, T C Ruhe, R W Watson, “Reactivity of ANFO with Pyrite containing weathering products”, US Bureau of Mines Report of Investigations 8373 (1979).



- Y. Miron, T C Ruhe and J E Hay, US Bureau of Mines Report of Investigations 8727 (1982).
- John Alfred Rumball, "The Interaction of Partially Weathered Sulphides in the Mt McRae Shale Formation with Ammonium Nitrate", PhD Thesis, Murdoch University, 1991
- D Tunaley, "An Emulsion explosive system for blasting in reactive volcanic conditions", Proceedings Fragblast 1999, South African Institute of Mining and Metallurgy, p313-319.
- Paul W Cooper, "Explosives Engineering", Wiley-VCH, New York, 1996; p 303
- TJ Briggs, IJ Kelso, "Ammonium Nitrate-Sulfide Reactivity at the Century Zn-Pb-Ag Mine, Northwest Queensland, Australia", 2002
- JC Miller and JN Miller, "Statistics for Analytical Chemistry", John Wiley and Sons, 1988
- P Priyananda, A M Djerdjev, J Gore, C Neto, J K Beattie, B S Hawkett, "Premature detonation of an NH_4NO_3 emulsion in reactive ground", Journal of Hazardous Materials, 283 (2015) 314 – 320.



SECTION 2 Regulatory Requirements

The Regulatory requirements for blasting in elevated temperature and/or reactive ground vary significantly from state to state. Some guidance is given in Sections 12.7 to 12.9, AS2187.2 but this does not adequately address how elevated temperature and reactive ground are determined and the precautions that need to be taken in the use of explosives in such ground. This Code attempts to address these short comings.



SECTION 3 Background

When dealing with the issue of elevated temperature ground and reactive ground, there are four main ground conditions that can apply:

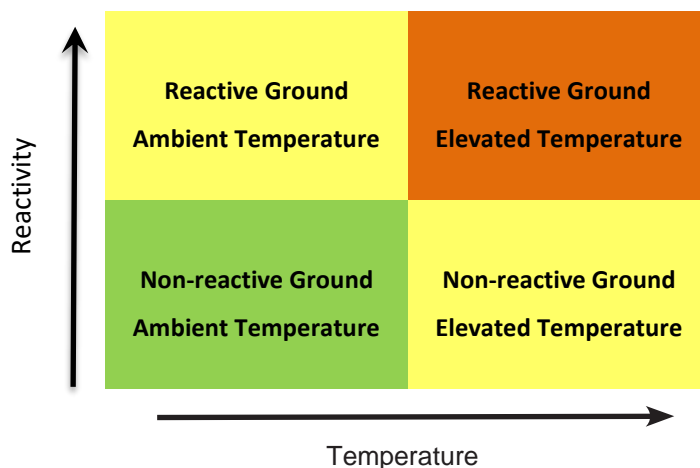

Within this Code, elevated temperature ground conditions will be covered first, followed by reactive ground conditions. For the case of both elevated temperature and reactive ground conditions, the risks associated with both conditions need to be considered during product selection and in determining operational requirements.

3.1 Case Histories

There have been a number of incidents that have occurred across the mining industry that have been associated with elevated temperature and/or reactive ground. Some examples are listed below:

Table 1 Examples of known incidents caused by elevated temperature and/or reactive ground

	Location	Type	Details of Incident
2016	Indonesia	H	Melted Booster
2014	Indonesia	HR	Premature Detonation
2014	Qld, Australia	U	Post blast detonation
2014	Chile	R	Premature Detonation
2014	Canada	H	Mass Detonation
2014	Qld, Australia	HR	Melted Downlines
2013	Chile	R	Premature Detonation
2013	NSW, Australia	H	Premature Detonation
2013	Qld, Australia	H	Melted Downlines



Date	Location	Type	Details of Incident
2012	Russia	R	Unknown
2011	Mongolia	HR	Premature Detonation
2010	NSW, Australia	HR	Premature detonation
2010	South Africa	H	Mass Premature Detonation
2010	NSW, Australia	H	Smoking Holes
2009	China	H	Mass Premature Detonation
2009	Qld, Australia	H	Premature Detonation
2009	South Africa	H	Premature Detonation
2009	Russia	R	NOx fume emanating from blasthole soon after charging
2008	Mt Gordon	R	Two hole deflagration
2007	Donaldson Coal	R	Spillage fire
2007	Canada	R	Premature Detonation
2007	Russia	R	Premature Detonation
2006	Curragh	H	Premature Detonation
2006	NSW, Australia	H	Melted Downline
2006	Mexico	R	Premature Detonation (ANFO)
2005	Black Star	HR	Premature Detonation
2005	Moura	H	Melted Primer
2003	Ernest Henry	R	Melted lead lines (2 leads in one hole)
2003	Drayton	H	Detonating cord caught fire on bench surface
2002	Collinsville	R	Melted primer
2000	Parkes	R	Spillage fire
1998	Century	R	AN spillage fire
1998	Ok Tedi	HR	Drill cuttings caught fire
Date	Location	Type	Details of Incident



1998	Sons of Gwalia	R	Smoking holes
1998	Southern Cross	R	ANFO spillage fire
1998	Collinsville	R	A hole loaded with sawdust/ANFO detonated prematurely
1997	Minahasa	U	Premature detonation
1995	Saraji	R	Spillage reaction
1995	Collinsville	R	Holes containing emulsion (heavy ANFO) caught fire
1994	New Hope	H	Premature Detonation
1992	Mt Leyshon	R	Premature Detonation
1991	USA	U	Premature Detonation with ANFO
1990	Dominican Republic	U	Heavy ANFO caused burning and premature detonation
1989	Mt Lyell	U	Premature Detonation
1989	USA	U	Battle Mountain Gold – premature detonations with ANFO
1989/90	Faro, Canada	U	Premature detonation
1987	Mt Whaleback	R	Premature Detonation with ANFO (hole liner split)
1983	Mt Whaleback	R	A hole loaded with ANFO detonated prematurely
1968	Russia	R	Premature Detonation with AN explosives
1963/ 64/65	Mount Isa	R	Premature Detonations with ANFO

Note: H = Elevated temperature ground only.
R = Reactive ground only.
HR = Elevated temperature AND reactive ground.
U = Information unavailable.



SECTION 4 Risk Assessment – Indicators of Reactive Ground

Due to the serious nature and high risk of unexpected detonations associated with the use of explosives in elevated temperature and/or reactive ground there are a number of strong indicators that mine and quarry operators (at both proposed and existing sites) should monitor. If any of these indicators are found then a detailed risk assessment of the use of explosives on the sites shall be carried out (including sampling and screen testing, refer to Sections 7 & 8) and, as the site develops, the reactive ground indicator risk assessment shall be reviewed at least annually or when conditions change within the mine (e.g. geology, mining methods, etc.) with due consideration given to all the indicators.

As well as historical data, indicators for the presence of reactive ground include: -

- the presence of sulphides;
- the presence of black sulphide bearing sediments;
- sulphides within mineralised rock;
- the presence of white or yellow salts on rock. This is an indication that oxidation is taking place;
- acidic conditions (generally resulting from oxidation) which may be indicated by the colour of run-off water, usually yellow-red brown in colour;
- significant corrosion of rock bolts, safety meshing and fixed equipment associated with the mining operation;
- the spontaneous combustion of overburden or waste rock/ore either in dumps or in the pit, especially as it is exposed to the air;
- the acrid smell of sulphur dioxide caused by the naturally occurring sulphide oxidation reaction;
- elevated blast hole temperatures;
- elevated ground temperatures.

It should be noted that a change in explosive provider does not mitigate the need to conduct a thorough review of past operations. Mine managers must notify the next explosives provider if the mine has been identified as having reactive and/or elevated temperature ground.

SECTION 5 Elevated Temperature Blasting

5.1 Principles for Elevated Temperature Management

The preferred approach to elevated temperature ground management is to mitigate the risks highlighted in the risk assessment process by quantifying the hazards and selecting the most appropriate mitigation measures. This will be achieved through a combination of suitable procedures and product selection.

Elevated temperature may be caused by reactive ground, however this section deals with ground that is at an elevated temperature but is NOT reactive.

5.2 Causes of Elevated Temperature Ground

Elevated temperature ground can exist due to one of the following conditions:

- geothermal heating – e.g. volcanic activity;
- geothermal gradients;
- burning coal seams;
- cement fills in stopes;
- thermal heating of ground surfaces by solar radiation.;
- sulphide oxidation – reactive ground is a special case of elevated temperature ground.

5.3 Risks and Hazards of Blasting in Elevated Temperature Ground

Elevated temperatures (i.e. temperatures above 55°C) will affect bulk, packaged and initiating explosives products over time, increasing the rate of degradation and potential failure which may lead to a misfire or an explosion.

Some of the major hazards associated with elevated temperature ground can be summarised as follows:

- exposure of operators to high temperatures;
- exposure of operators to toxic vapours;
- ignition of vapours associated with emulsion and ANFO type products;
- softening of plastic components of initiating products;
- melting and decomposition of bulk, packaged and initiating products;
- detonation following decomposition.

5.4 Risk Management through Operating Practices

Once a site has been identified as having elevated temperature ground conditions, the operating procedures and on-bench practices need to be adjusted accordingly to minimise the hazards outlined above. These should include:

5.4.1 Site Specific Operating Procedures

Site specific operating procedures need to be developed involving all key stakeholders based on a risk assessment and including all appropriate control measures. Documented control and change management procedures must be put in place to ensure all key stakeholders are formally notified of any intention to change these procedures and agreement reached on the changes.

Areas to be included in site specific operating procedures include:



- training;
- sleep time;
- hole temperature monitoring;
- hole loading sequence;
- delineation of zones;
- product selection;
- spillages.

5.4.2 Training

The customer is responsible for ensuring that training in blasting in elevated temperature procedures occurs. Training is to extend to all personnel operating on the bench or involved in the management of these personnel. Training shall also include regular reassessment. (See also Section 14.)

5.4.3 Sleep Time

The sleep time of products in elevated temperature ground shall be minimised to prevent unnecessary heating of products, which may lead to product deterioration and a possible unplanned event. Reference should be made to the Technical Data Sheet for the explosive product, or to a technical representative of the explosives provider.

Note: Hole temperature is often linked with the recommended sleep times (the higher the temperature, the shorter the sleep time).

5.4.4 Hole Temperature Monitoring

Hole temperature monitoring is a critical part of the risk management process for the following reasons:

- it allows for hole-by-hole classification of temperature – not all holes may be hot and hence different products may be suitable for different areas;
- identifies if hole temperature is changing with time;
- identifies holes with temperatures in excess of the allowable loading temperature, so that they can be left uncharged or backfilled.

The temperature logging procedure, including the frequency of measurement, shall be recorded in the site-specific procedures. Key principles for effective temperature logging include:

- selection of a measurement device with a suitable temperature range and a measuring system suitable to the conditions (e.g. infra-red may not be effective in wet holes or steaming holes);
- hole-by-hole logging;
- recording maximum hole temperature;
- frequency of measurement;
- recommendations on how to act on the temperature information.

Refer to appendix 6 for more information and a discussion of current measurement techniques.

5.4.5 Hole Loading Sequence

When working in elevated temperature areas, it is preferable that loading occurs near the initiation point first (i.e. load in the sequence in which the blast will be fired). This is to allow the pattern to be quickly tied in and fired in the event of a change in conditions (e.g. weather or approaching maximum allowable sleep time). Where practical, allow for the hottest holes to be loaded last.

5.4.6 Occupational Health and Safety Considerations

Areas of elevated temperature ground may lead to exposure of personnel to scalding from steam or hot water. Toxic gas such as hydrogen sulphide and carbon monoxide may also be generated under these conditions.

5.4.7 Delineation of Zones

Delineation of ground into elevated temperature and non-elevated temperature zones can occur after multiple hole-by-hole temperature measurements. Delineation allows for the choice of different explosive products, the setting of sleep time and if necessary the backfill of holes on a hole-by-hole basis.

5.4.8 Spillages

During charging of blast holes there is a possibility that spilt explosives may react where benches are at an elevated temperature. Procedures for minimising spillages of explosives need to be developed and where possible spillages must be cleaned up immediately. The procedures should also ensure that initiating systems do not come into contact with the spilt explosives as the possible decomposition of the explosive may cause the initiation system to degrade or detonate.

5.5 Risk Management through Physical Separation

Generally, the use of physical separation to insulate explosives from elevated temperature ground is not recommended. If this approach is taken then the associated risk assessment must take into account all hazards and all likely failure modes to ensure that an appropriate level of safety is achieved and can be maintained. (Note: Details in Section 6.5 should also be considered.)

5.6 Risk Management through Product Selection

Choice of bulk, packaged and initiating explosive product can be a particularly effective way of addressing the risks associated with elevated temperatures. All products must be used in applications stated as per their Technical Data Sheets which shall indicate whether or not products are suitable in elevated temperature applications.

Where a site is known to have elevated temperature ground conditions, the following products may be suitable for use:

- bulk products – these need to be formulated to withstand elevated temperatures; and
- initiating and packaged products – these need to be formulated and/or packaged to withstand elevated temperatures.



SECTION 6 Reactive Ground Blasting

6.1 Principles for Reactive Ground Management

Reactive ground is a condition specific to individual sites. Case histories (see Section 3.1) indicate that in the past this type of condition has only been identified following an incident. The preferred approach to reactive ground management is to be as pro-active as possible, by identifying and minimising the recognised risks rather than responding post incident. It is not possible to completely eliminate all risks as it is not possible to account for the characteristics of every section of rock. However, there are risk management approaches that can be and have been successfully adopted that provide acceptable safety margins thus preventing incidents occurring. This Section of the Code covers a number of recommended risk management approaches.

6.2 Chemistry of Reactive Ground

The reaction of nitrates with sulphide containing minerals is an auto-catalysed process that can, after some induction time, lead to a runaway exothermic decomposition even if the starting temperature of the mixture is ambient. Typical nitrates used in the explosives industry include (but are not limited to) ammonium nitrate, calcium nitrate and sodium nitrate. The reaction scheme developed over the last 30 years of research by groups such as the US Bureau of Mines (USBM) and others is described in a simplified form below (reference - John Rumball's thesis, "The Interaction of Partially Weathered Sulphides in the Mt McRae Shale Formation with Ammonium Nitrate").

Natural oxidative weathering of iron sulphides such as pyrites by atmospheric oxygen and microbes, generate solutions of ferrous ions and acid. This process occurs whenever the sulphides are exposed to air along cracks, in drilled holes, in the muck pile after blasting, on pit walls and in old stopes. No nitrates are required for this to occur.

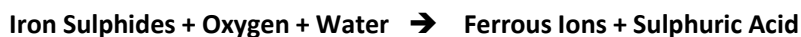

This reaction is exothermic and can lead to hot blast holes for particularly reactive ores. This temperature increase can be minimal or as much as several hundred degrees.

On contact with ammonium nitrate, the ferrous and acid species from weathering can begin to catalyse the breakdown of nitrate. The breakdown process is auto-catalytic in that it generates its own catalysts as it proceeds.



The nitric oxide and ferric ions produced in this stage react with more pyrites, generating more ferrous ions and sulphuric acid.



Although these reactions are exothermic, their rate may be initially so slow that little or no temperature rise is detectable. This is due to the time taken for the concentration of the catalytic species to build up to some critical level. The time taken for this to occur is often referred to as the induction period. When sufficient catalysing species have built up, the reaction rate increases sharply and the heat generated causes the temperature to become so high that a rapid, potentially violent decomposition of the remaining ammonium nitrate is inevitable.



Reactive ground incidents have occurred at many sites which had previously operated for considerable periods of time loading uninhibited product. For this reason, a history of loading uninhibited products without incident is not a valid control for use as a basis for safety for blasting safely in reactive or potentially reactive ground.



6.3 Risks and Hazards – Blasting in Reactive Ground

The hazards associated with blasting reactive ground can be summarised as follows:

- sudden violent decomposition of nitrates;
- evolution of toxic NO_x and SO_x fumes;
- unexpected detonation of detonators due to the heat generated;
- mass detonations:
 - deflagration-to-detonation in single holes (heat generated causes the contents of the hole to catch fire and then to detonate);
 - communication to other holes via initiating systems

6.4 Risk Management through Operating Practices

Once a site has been identified as having reactive ground conditions, the operating procedures and on-bench practices need to be adjusted accordingly to minimise the risks outlined in Section 6.3. These should include the issues outlined hereunder.

6.4.1 Site Specific Operating Procedures

The customer is responsible for ensuring that site specific operating procedures are developed involving all key stakeholders. Appropriate document control procedures shall be put in place to ensure all key stakeholders are formally notified of any intention to change the procedures and agreement is reached on these changes. Areas to be included in site specific operating procedures may include:

- training;
- sleep time;
- hole temperature monitoring;
- shot design in reactive ground blasting;
- hole loading sequence;
- stemming material;
- product spillage;
- overfilling of holes;
- occupational health and safety considerations;
- ongoing review of risk assessment;
- delineation of zones;
- emergency plan (or specific inclusion for reactive ground in general site emergency plan).

6.4.2 Training

The customer is responsible for ensuring that training in reactive ground blasting procedures occurs. Training is to extend to all personnel operating on the bench or involved in the management of these personnel. Training shall also include regular reassessment. (See also Section 14.)



6.4.3 Sleep Time

The sleep time of product in reactive ground should be kept to a minimum to reduce the exposure time of nitrate based products in potentially reactive material. The maximum sleep time is determined by the explosives supplier based on testing of site specific reactive ground to ensure suitable inhibition time is achieved. (See also Section 8.3.)

6.4.4 Hole Temperature Monitoring

In reactive ground, there is a risk that after drilling holes, the hole temperature may rise above ambient conditions due to oxidation of the ground material with air. It is important to monitor hole temperatures to confirm that the ground does not rise above a temperature in which the selected product is appropriate for use in both elevated temperatures and reactivity conditions.

Where it can be shown, through an extensive measurement campaign, that in hole temperatures in reactive ground do not exceed those considered ambient, it may not be necessary to monitor hole temperature on an ongoing basis. However areas may heat over the lifetime of the mine, therefore campaign testing and ongoing review and risk assessment of the site temperature monitoring procedures should be carried out. The requirement for monitoring of hole temperature (or not) shall be specified in site specific procedures. These procedures may specify suitable methods for rapid detection of hot holes, such as thermocouples, IR guns and/or thermal imaging equipment however the procedures shall ensure that the maximum temperatures are recorded. The equipment used shall be tested for accuracy prior to use. Note – Equipment suitability must be considered, for example, IR guns cannot be used for holes that contain water.

Refer to appendix 6 for more information and a discussion of temperature measurement techniques.

6.4.5 Shot Design in Reactive Ground Blasting

When blasting in reactive ground, consideration must be given to designing shots to minimise the risk of hole dislocation during blasting, i.e. maximise the use of free face where possible and avoid box cut type designs. Hole dislocation can potentially lead to misfires or bulk product remaining in the ground for longer than the recommended sleep time.

If decked shots are required in reactive ground areas, an additional risk assessment should be completed to identify any additional risks (potential for increased dislocation of charges) with the appropriate risk mitigation being put in place prior to the shot. Consideration should also be given to plans to dig out misfires within the recommended sleep time of the product.

6.4.6 Hole Loading Sequence

When working in reactive ground areas, it is preferable that loading occur near the initiation point first (i.e. load in the sequence in which the blast will be fired). This is to allow the pattern to be quickly tied in and fired in the event of a change in conditions (e.g. weather, approaching maximum allowable sleep time, or signs of reaction).

6.4.7 Stemming Material

When blasting in reactive ground applications it is highly recommended that stemming is carried out with non-reactive materials. In particular stemming with drill cuttings is to be avoided. This is because the fine particle sizes associated with drill cuttings maximises the surface area available for contact with the explosives resulting in an increased likelihood of reaction.



It is a well established principle that increasing the surface area of contact between two potentially reactive materials significantly increases the probability and rate of reaction.

6.4.8 Product Spillage

At all times the spillage of explosives on the bench should be minimised and eliminated if possible. This is due to the possible interaction of the explosive and potential or proven reactive surface rock/drill cuttings.

6.4.9 Overfilling of Holes

At all times the overloading of holes in reactive ground should be avoided. To prevent overloaded holes, ensure loading takes place with enough manning to have someone dipping holes while loading. An overloaded hole should not be washed out.

6.4.10 Occupational Health and Safety Considerations

Areas of reactive ground may generate sulphur dioxide and sulphuric acid which may affect people operating in the area as well as process equipment. Site specific procedures need to include guidelines for:

- evacuation procedures when sulphur dioxide reaches a critical limit;
- personnel to wear appropriate gas monitoring equipment and breathing apparatus when necessary.

6.4.11 Ongoing Review of Risk Assessment

Sites shall be assessed for indicators of reactive ground annually or when any of the following changes occur:

- changes in geology – e.g. different levels of sulphides;
- changes to blasting practices – e.g. sleep time requirements;
- changes in explosive product;
- changes in explosives provider;
- change in the degree of oxidation/reaction.

Reactive ground sampling and testing shall be conducted from those areas which show indicators of reactivity, to ensure the following:

- ground conditions at the site are monitored to understand ongoing conditions as production moves into different areas – this applies to both known reactive ground areas and also areas that have not been classified as such;
- for reactive ground sites, to determine product selection appropriate to the current level of reactivity in order to reduce the risk of a reaction;
- to increase understanding of the critical areas of reactivity on the site or to uncover reactivity in areas that have not previously been identified.

Refer to Section 8 for frequency of ongoing reactive ground testing based on the risk profile of the site.

6.4.12 Delineation of Zones

Delineation of a site into reactive and non-reactive ground shall only occur after significant research into the nature and extent of reactivity has been carried out. In some cases it may not be possible to delineate and the entire site should be classified as reactive.

Delineation requires close cooperation between those with geotechnical expertise and explosive providers based on reactive ground sampling and testing.

Delineation of a site should not occur if there are no clear indicators as to what ground is reactive and what is not. This particularly applies to so called 'vertical delineation' of mines, or sections of mines. In addition to risks identified with delineation, knowing when operations are entering or approaching the transition zone (oxidised to partially oxidised sulphides) as the mining progresses is very important. Another potential risk could be associated with the leaking of dissolved nitrates through the ground from the shot above into the reactive area below.

Consideration should be given to the possible sources of contamination of reactive material to non reactive areas and ensure suitable controls are in place.

Delineation may be possible if there are:

- clear zones of geological type;
- clear zones based on sulphide levels;
- drill cuttings that are geologically logged for the presence of sulphides and a procedure is in place for utilising this information to determine what product is to be loaded into the reactive and non reactive holes;

If delineation is established across a site appropriate buffer zones between reactive and non-reactive areas must be established and rigorously managed. Procedures for the loading of explosives into the two areas needs to be developed, and must include a detailed emergency action plan should uninhibited product be loaded into reactive ground.

Communication procedures should be developed to ensure all departments and contractors involved in the drill and blast process on a delineated site have clear lines of communication to ensure the correct product is loaded into reactive ground.

Products should be easily identifiable to reduce the risk of loading uninhibited product into reactive ground.

6.4.13 Emergency plans

It is recommended that reactive ground sites have a reactive ground emergency plan, or include the management of reactive ground incidents as a part of their site emergency plan.

The emergency plan should include controls to manage misfires and premature reaction/detonation events in reactive ground, with further information found in Sections 11 and 12 respectively.

Additionally, for sites that load both inhibited and uninhibited products, it is recommended to have a procedure in place should uninhibited (or insufficiently inhibited) product be loaded into reactive ground. This may include washing bulk products out immediately, tying in the shot immediately to be fired, or removal of the product.

6.5 Risk Management through Physical Separation

Barriers which prevent explosive products coming into contact with reactive ground have been used in the past for reactive ground applications. Such barriers include the use of blast hole liners for bulk explosives

and the use of cartridge explosives. However, for reactive ground applications, the use of blast-hole liners (with uninhibited bulk explosives) and uninhibited packaged products should be discouraged. The use of barriers is not industry 'best practice' and has led to unacceptable incidents of uninhibited products being exposed to reactive ground at an extremely high risk.

6.5.1 Blast Hole Liners

Blast hole liners may prevent uninhibited bulk explosives coming into contact with reactive ground but have severe limitations which may impose a significant increase in risk, such as:

- Liners may split exposing uninhibited product to reactive ground;
- Overall strength and suitability of the liners may not be applicable for all conditions or to changes in conditions that may occur (e.g. variations in temperature with time) on the bench to which they are being subjected;
- Liners do not prevent material that is spilt on the bench from reacting;
- Bulk explosives may be spilt down the side of the liner potentially allowing uninhibited product to contact reactive ground;
- If a primer misfires damaging the liner but leaving bulk product unfired, uninhibited product would be left to potentially react;
- Loading times may increase due to handling issues associated with liners on the bench.

Using liners and standard uninhibited explosive products, and assessing the associated increased risks at a particular site will be a decision that the site operator will need to determine through risk assessment.

6.5.2 Packaged Explosives

The use of packaged explosive products where the outer casing (e.g. plastic, paper or cardboard) acts as a physical barrier is also an option. The outer casing may prevent the explosive content coming into contact with reactive ground but like blast hole liners have limitations such as:

- Generally only suitable for small blasts as costs may become prohibitive;
- The loading of packaged product may involve the splitting of the casing (for the insertion of the initiators or damaged during charging) which will compromise the layer of protection;
- The outer casing may not be ground water or tear resistant leading to the casing being breached;
- Damaged or misfired cartridges could be left in the muck pile with the potential to react.

The use of uninhibited packaged explosive products and assessing the associated increased risks at a particular site will be a decision that the site operator will need to determine through risk assessment.

6.6 Risk Management through Explosive Product Selection

The use of suitably inhibited products has been shown to be the most effective method of addressing the risks associated with reactive ground. All explosive products must be used in applications stated as per their Technical Data Sheets and through compatibility testing with the ground in question (see Section 8 for further details). Explosives providers shall indicate in Technical Data Sheets whether or not explosives products are suitable in reactive ground applications.



Where reactive ground conditions exist within a site, the following products may be suitable for use:

- bulk products – inhibited products with recommended sleep times based on compatibility testing with reactive ground;
- initiating products – products suitable for reactive applications;
- packaged products – inhibited products with recommended sleep times based on compatibility testing with reactive ground.

Following explosive product selection, and during loading, the use of “start-up” and “clean out” product shall be carefully monitored. This start-up and clean out product should be loaded into non-reactive blast holes wherever possible. Alternately, the product should be manufactured into a bucket for later disposal as active stemming in non-reactive blast holes. In situations where this is not possible, then the product should be manufactured in an emulsion-rich state by the MPU operator.

Variation in explosive product selection should also be considered in the event of having to extend sleep time beyond current limits. For example, when machine breakdown occurs on bench or in an electrical storm. A higher emulsion content product will have more inhibitor (if the inhibitor is contained within the emulsion), and therefore a greater safety margin.

SECTION 7 Sampling for Reactivity Testing

7.1 Sample Selection

Reactivity sampling and testing is a crucial component of reactive ground management. It must be noted that it is rarely possible to statistically take enough rock samples to fully characterise the geology and hence the reactivity of a site. Testing, and in particular screening for reactivity, needs to be targeted to analyse the rocks containing sulphides in order to identify the “worst case” reactive rock samples and hence to minimise the risk of incidents. Other indicators listed in Section 4 may be used to identify the most likely locations from where rock samples should be taken.

The role of geotechnologists (e.g. site and consulting geologists) is essential for the identification of samples with a high potential for reactivity. Where possible, the expertise of site geotechnologists shall be employed and geological knowledge (targeting sulphides) shall be used to implement safety margins and to compensate for the limited numbers of representative samples. The sampling method requires selection of “worst-case” samples present on the site at that point in time

Samples should be taken so that their exact location is known. Samples picked from a wall or drill core samples are the most useful for screening purposes. Samples picked up from the floor may have fallen from a much higher point or been moved from a different location and hence are less useful when it comes to identifying risk zones. Drill cuttings can result in “diluted” rock samples and allow for some oxidation to occur before testing – hence the best samples are whole rocks from known locations.

7.2 Handling of Samples

In order to obtain accurate results, testing shall occur just prior to explosive supply commencing using fresh samples (i.e. newly exposed rock rather than old core drill samples). This is to ensure that the effects of oxidation do not “hide” potentially reactive samples.

7.2.1 Sample Size

Sample size should be appropriate for the testing that is to be carried out. For standard laboratory scale screen testing or verification work, a minimum of 0.5kg with the maximum rock size approximately “fist-size” (i.e. 50mm diameter).

7.2.2 Sample Identification

To ensure the traceability of samples back to their location on the site, records are to be kept of sample identifications, collection points and date of collection.

7.2.3 Sample Packaging

The following considerations shall be made when packaging:

- packaging can easily be linked with a sample (e.g. indelible markings);
- packaging is to be robust enough to prevent rupture (and potential mixing) of samples;
- where it is not possible to collect whole rock samples (e.g. when only rock chips or drill cuttings are available), samples are to be taken immediately after drilling and stored in sealed plastic bags to minimise oxidation through exposure to oxygen (vacuum sealing is preferred where available).

7.2.4 Sample Timing

Allow a suitable time between the collection of samples and the time frame in which the area is to be blasted. A suitable time may vary depending upon the explosives provider and the length of sleep time test required. However, 3 months would generally be a reasonable time.

7.3 Sampling for Initial Screening

A “green field” site refers to the following scenarios:

- new site that has never been excavated;
- excavation commencing in a new development on an existing site;
- excavation commencing in an area of untested geology;
- where this Code has not been applied.

Before site development commences a risk assessment of the site should be carried out based on Section 4. If no indicators are present then it may be assumed that the site is non-reactive.

If the risk assessment indicates the likelihood of reactive ground, the ground shall be tested for reactivity as per the Isothermal Reactive Ground Test. The role of site geotechnologists is essential when identifying high potential samples that characterise the most potentially reactive ground. At this initial stage, sulphide analysis can be used to target areas (as a minimum) to eliminate the need to take samples from areas that contain no sulphides.

The minimum recommended number of samples selected and collected for testing is 12. The most suitable number is difficult to quantify but they should be a well-chosen set of samples (i.e. obtained with assistance from geotechnologists), following a documented risk assessment procedure. Best practice is to take samples from each region of the site and from each strata within that region that contain sulphides. If the sulphide content is unknown, then samples must be taken.

Refer to Flowchart in Section 13 for further information.

7.4 Sampling for Ongoing Testing

Periodic testing at a known reactive ground site is an important part of the reactive ground risk management process for the following reasons:

- to clarify the extent of reactivity at a known reactive site;
- to confirm that the level of chemical inhibitor used at the site remains sufficient to continue to inhibit a reaction within the recommended site sleep times;
- to allow for extensions of sleep time to meet the needs of the customer;
- to assess whether changes in raw material sourcing effects the ongoing suitability of the explosive product for the established conditions.

7.4.1 Existing site – No previous reactivity

Even if sites have shown no previous signs of reactivity, ongoing testing shall continue on a regular basis according to the risk profile of the site (if there is no major excursion from the initial risk assessment, then retesting may not be required). The level of ongoing testing, based on the risk profile, may need to be agreed between the site operator and the explosive supplier.

Site geologists shall initiate retesting if entering a “green field” zone or an area that is yet to be blasted and contains geology that has not been tested for reactivity. Retesting, however, is not required if the indicators as detailed in Section 4 are absent from the geology of the specific zone/area.



The minimum recommended number of samples is 12. Samples are to be selected based on records of core sampling and mineral analysis or ore body mapping.

7.4.2 Existing site – Reactive ground site

For sites that have shown evidence of reactivity (through either incidents or positive reactive ground testing results), a suitable ongoing sampling program shall be set up and included in site operating procedures. At a minimum, retesting shall occur every 12 months. A qualified site geologist shall select at least 12 samples in order to try and obtain the most reactive samples.

The aim of this testing is to ensure that the recommended products are still sufficient to prevent a reaction and hence maintain the basis of safety.

Table 2 Frequency of Sampling Summary – Based on a Risk Profile of the Site

Type of Site or Scenario	Frequency of Testing	No. of Samples
Screening at “Green Field” sites: <ul style="list-style-type: none"> • New site that has never been excavated. • Excavation commencing in a new development on an existing site. • Blasting commencing in an area of untested geology (identified by on-site geology). • Where this Code has not been applied. 	Before commencing development in the new area.	Recommended minimum of 12. (Number of samples to be determined between explosives provider and customer). Best practice is to take samples from each region of the site and from each strata within that region that contain sulphides
Ongoing testing at: <ul style="list-style-type: none"> • Non-Reactive sites (non- inhibited products in use). • Reactive ground sites (inhibited products in use, no change in geology). 	Annual testing.	Minimum of 12.
Ongoing testing at: <ul style="list-style-type: none"> • Reactive ground sites (inhibited products in use, change in geology). 	Testing required prior to blasting in area	Minimum of 12.

SECTION 8 Reactive Ground Testing and Product Selection

8.1 Introduction

In order to identify reactive ground and to determine the effectiveness of inhibited product in preventing reactions, laboratory scale test methods have been developed. There are two separate steps that need to be considered when discussing testing procedures:

- Reactivity Screening – this test method is used to identify whether ground samples are reactive toward ammonium nitrate;
- Product Selection Testing – this test method is used to confirm whether an inhibited product is suitable for a specific reactive application.

It may also be appropriate on some sites to carry out additional large scale testing for reactivity and to ensure the ongoing suitability of selected bulk explosive products for use in reactive ground. This form of testing should not be used as a replacement for the laboratory Isothermal Reactive Ground Test, however, it may give customers the opportunity to carry out their own evaluations of products under local site conditions.

The procedure for Reactive Ground Testing and Product Selection is detailed in the Isothermal Test Method in Appendix 3.

8.2 Reactivity Screening

Reactivity Screening is laboratory testing used to determine if the site samples, specifically selected as per section 7, react with ammonium nitrate and consequently have the potential to react with ammonium nitrate based explosives. The samples which are shown to be reactive are then used in determining the suitability of explosive products to be used within the ground.

8.2.1 Isothermal Reactive Ground Test

The Isothermal Reactive Ground Test has been developed for use in screening reactive samples and for carrying out sleep time analysis. “Standard” test conditions are used when blasting is to occur in normal temperature ground (i.e. 55°C). However, if the risk assessment indicates that a higher temperature may be experienced, then the highest nominated loading temperature should be adopted as the minimum standard temperature for that site, and consequently isothermal testing will occur at this temperature.

A summary of the test steps is outlined below with the detailed test procedures given in Appendix 3.

- Rock samples are crushed to a fine powder.
- The rock powder is then mixed with chemically pure ammonium nitrate and a solution to simulate the by-products of sulphide rock weathering.
- The mixture is heated to and kept at $55^{\circ}\text{C} \pm 2^{\circ}\text{C}$, (for non-elevated temperature ground sites) the adopted standard temperature, and monitored for exothermic reactions. For elevated temperature ground sites, the test is performed at a temperature no lower than the maximum recorded in-hole temperature based on temperature logging and historical data, or no lower than the maximum nominated temperature limit at the site.
- If exceptionally long sleep times are required in specialised blasting applications, a detailed risk assessment should be conducted by the site operator and the explosives supplier. It may also be appropriate to use a Temperature Ramping Test (see Section 8.2.2)

- The mixture is monitored for any visual reactions (such as colour change or signs of chemical reactions such as gas liberation) and reactivity is identified by a change in temperature, detected using thermocouples with continuous temperature logging.
- This test method is capable of picking up exotherms of 1°C and greater that are above the background temperature. Samples that exhibit an exotherm of 2°C or more are classified as reactive and require further investigation.

A reactive response is identified by an increase in temperature from the base line test temperature. As outlined in the definitions (Section 1.2), the “reactivity” of a sample or the ease at which a sulphide/nitrate reaction occurs is related to the induction time. For example, a series of samples can be ranked as “most reactive” to “least reactive” under the same test conditions according to the time taken to react with the “most reactive” sample reacting first. The “intensity” of a reaction is related to the size of the exotherm and does not relate to the induction time.

8.2.2 Temperature Ramping Test

The Temperature Ramping Test may be a useful test for efficiently identifying samples which could be reactive from a large number of samples.

Sample preparation is as for the “Isothermal Reactive Ground Test”. Testing is carried out by subjecting the prepared sample to a linear temperature increase over time until a reaction occurs. Samples which exhibit exothermic reactions at temperatures below the normal decomposition temperature of ammonium nitrate would be considered reactive. While this test does not give a direct measure of induction time, samples can at least be ranked according to the onset temperature of the exothermic reaction (the most reactive samples having the lowest onset temperature). The most reactive samples can then be checked for induction time in the isothermal test.

A detailed test method for the Temperature Ramping Test is not provided in this Code as the Test is not widely used. The details of any proposed Ramping Test Method and the intended interpretation of results would need to be agreed before it can be adopted into the Code.

8.3 Product Selection Test

The results from the reactivity screening tests indicate which rock samples are classified as reactive. The reactive samples are retested against the intended explosive to be used in the ground. This must be done to determine the most appropriate formulation and sleep time.

The “Isothermal Reactive Ground Test” is repeated replacing the ammonium nitrate with the inhibited explosive. A range of products may need to be assessed to determine which one is suitable for use in the reactive ground so that adequate sleep time is achieved. Each explosive provider will use their own methods (formulation, ingredient selection and inhibitor levels) of ensuring that their products are suitable for the reactivity conditions under investigation.

8.3.1 Sleep Time Testing

Sleep time testing is used to determine the maximum sleep time which may be used for the selected product. Sleep time testing involves testing reactive ground with inhibited product using the “Isothermal Reactive Ground Test” for a period equivalent to four times the required product sleep time, up to a maximum test period of 28 days.

For existing reactive ground sites, the maximum recommended sleep time in reactive ground is one week (i.e. laboratory test for 28 days). Beyond this period, a risk assessment involving the explosives provider and the customer should be carried out and documented, and consequently



extended laboratory sleep time testing may be appropriate. There may be a requirement to advise the outcome of the risk assessment to the appropriate regulator.

8.3.2 Additional Product Testing

As well as using the “Isothermal Reactive Ground Test” for product selection with an appropriate sleep time, additional product testing must be carried out should any of the following changes occur:

- use of a new or different bulk explosive product especially from a new supplier;
- raw material sourcing or significant formulation changes of the existing explosive product;
- increases in the required product sleep times;
- changes to site geology;
- changes in ground temperatures.

8.4 Large Scale Testing

For some sites and as part of ongoing reactive ground management, testing in the form of the on bench bucket tests may be appropriate. In the bucket test several kilograms of crushed ground are combined with the inhibited product and left on bench for an extended period. Details of the test are given in Appendix 4.

Large scale methods are not as sensitive as the isothermal test and should not be used as a substitute for the isothermal test, however they can be used to provide supplementary information.

Some benefits of completing the Bucket Test may include:

- enables the on-site testing with fresh ground samples from known locations and with site manufactured explosive products;
- testing is visible to the site operator;

The bucket test, using ANFO, if carried out regularly, may be used as a method of monitoring the ongoing “reactivity” across a site, but this should not be used to replace the isothermal test.

The bucket test only detects when the reaction progresses to the final stage of the auto-catalytic reaction. It does not detect reactions that (for whatever reason) do not progress to the final stage of reaction, but could still potentially result in a premature detonation in-situ.

8.5 Recommended Testing Agencies

The test methods outlined above for screening potentially reactive samples and selecting suitable inhibited products should be carried out by the following groups:

- explosives providers with the appropriate laboratories and trained personnel;
- site and independent laboratories with the appropriate equipment and trained personnel.

All testing laboratories must ensure compliance with the relevant explosive regulations. The performance of laboratories must be assessed at least annually to ensure compliance with this Code.

Assessment of compliance for laboratories conducting the Product Selection testing should be through self-assessment by the explosives provider using appropriately-trained and experienced personnel. Explosives providers shall also conduct assessments of any site or independent laboratory that is conducting reactivity testing for customers utilising that explosive provider’s products. Records of the assessments shall be retained indefinitely by both the assessors and the laboratories.



A recommended guideline for the assessment of laboratories for operation in accordance with this Code is contained in Appendix 5.

Within the laboratory, appropriate precautions must be in place to ensure the safety and security of ammonium nitrate and explosives at all times. In some jurisdictions the laboratory may need to be approved and licensed to handle ammonium nitrate and explosives by the relevant statutory authority.

SECTION 9 Elevated Temperature and Reactive Ground Blasting

Where a site is known to have both elevated temperature and reactive ground conditions, explosives products that are suitable for withstanding the elevated temperature conditions in addition to the level of reactivity shall be used. All the precautions as detailed in Sections 5, 6, 7 and 8 of the Code must be applied. Greater vigilance in determining the “reactivity” of the ground is required due to the high ground temperatures promoting the nitrate/sulphide reaction.

9.1 Implementation of Elevated Temperature and Reactive Ground Products

Typically when the performance requirements for reactive ground products are being defined, the focus is on sleep time limitations. Consequently, other aspects of the full life cycle of the product may not be fully considered, right from the ground being dug through to loading the holes and including the consideration of misfires. Therefore, current blasting practices at site need to be risk assessed across the full reactive ground life cycle. Moreover, during product implementation, risk assessments should place greater emphasis on potential controls if delays, such as misfires, impose extended sleep times beyond established limits. The risk assessments should include multidisciplinary input from both the site and the explosives supplier, including: shotfiring, technical service, geology, engineering, and explosive product specialists.

Training programs covering the signs of a reactive ground event for personnel involved with managing any misfires should also be developed and conducted on a regular basis (reviewed yearly).

9.2 Shot Design in Elevated Temperature and Reactive Ground Blasting

When blasting in reactive ground consideration must be given to designing shots to minimise the risk of hole dislocation during blasting, i.e. maximise the use of free face where possible and avoid Box Cut type designs. Hole dislocation can potentially lead to misfires or bulk product remaining in the ground for longer than the recommended sleep time.

If decked shots are required in reactive ground areas, an additional risk assessment should be completed with the assistance of specialists from the explosives supplier. When blasting decked shots in reactive ground, consideration should be given to the use of electronic initiating systems to lower the risk of hole dislocation or misfires.

Prior to the shot, consideration should also be given to plans to dig out misfires within the recommended sleep time of the product should upset conditions occur.

9.3 Delineation by temperature

Where there is a risk of elevated temperatures on a site, blasthole temperature shall be measured with an instrument suitable for the specified temperature range and placed in the blasthole for a sufficient length of time to give a stable reading.

The temperature should be measured along the length of the blasthole with the highest temperature measured allocated to the blasthole. When hot material is indicated in any blasthole, the temperature of all the holes in the material to be blasted shall be measured within 24 hours of the beginning of the shift in which charging commences.

Hole temperatures should not be measured less than 2 hours after drilling, breakthrough holes shall be sealed for 4 hours prior to taking the measurement. [AS 2187.2 pg. 57].

If sufficient hole by hole temperature data is available, ground can be delineated by temperature bands relevant to the temperature and sleep time properties of the explosive system (bulk product and initiating systems) used.



The risk assessment for the shot should include the following points at the maximum nominated temperature of the delineated range:

- Appropriate reactive ground testing;
- Recommended sleep times of all components of the blasting system (Detonators/boosters/downlines/surface delays/Bulk Products);
- A process to ensure temperatures do not exceed the nominated temperature over the duration of the sleep time;
- Buffer zones between holes that exceed the nominated temperature;
- Procedures to identify and prevent loading of holes that exceed the blasting system limit.

Blast hole temperature can vary over time. Strategies such as temperature trending, where the blasthole temperature measurement is repeated over time with the temperature trend extrapolated to estimate the maximum temperature over a short sleep time, can be considered. Where temperatures are increasing over time particular care should be taken.



SECTION 10 Selection of Accessories

Initiating explosives used in elevated temperature and/or reactive ground conditions must be compatible with the high explosives they are to be used with and the environment in which they are to be used. Relevant technical data sheets should be consulted and the suitability or otherwise of the initiating explosives discussed with the supplier.

As a guide most commonly used initiating systems like detonators and Pentolite boosters may be used at temperatures up to 70°C. For initiating systems above these temperatures consult your explosives supplier.

Explosive	Melting Point
HMX	275°C
HNS	318°C
Pentolite	70°C
PETN	141.3°C
RDX	204°C
TACOT	378°C
TATB	350°C

Some initiating explosives, particularly boosters, may contain nitrates and therefore appropriate precautions as detailed in this Code must also be taken when used in reactive ground. Booster formulations must be enclosed in a suitable packaging capable of withstanding the chemical environment and temperatures encountered in the application of use. This can range from plastic coating, treated cardboard, tin cans and other metal containers or high temperature plastics.

SECTION 11 Procedures for Misfires & Extending Sleep Time

Misfire procedures need to take into account the increased risk of blasting reactive and/or elevated temperature ground and in particular, the increased exposure time of products to elevated temperature and/or reactive ground in the event of a misfire.

A risk management process is required in both the event of a misfire and the instance that sleep times are extended beyond the recommended values. In the event of a misfire, the explosives provider shall be involved in the misfire investigation. The customer shall contact the explosives provider to inform them of the situation. Details of the product used in the area will be provided and a reassessment of the recommended product range may be required.

In the first instance it is critical that for any misfire:

- an Emergency Evacuation Plan is developed, and communicated to all personnel involved in managing the misfire, covering what should be done should a reaction be observed during the recovery of the misfire;
- an exclusion zone is put in place around the misfire area for activities not directly associated with the recovery of the misfire;
- personnel on bench are minimised to only those directly involved with the management of the misfire;
- the charging of associated patterns, which are hot/reactive and whose firing could negatively impact on misfire recovery proceedings, immediately cease.

11.1 Misfires in Elevated Temperature Ground

Standard misfire procedures are applicable unless explosive exposure time is likely to go beyond the recommended sleep times. In addition to standard misfire procedures, water may be used to wash out elevated temperature holes, though it must be noted that water temperature may become hot with exposure to hot ground conditions.

11.2 Misfires in Reactive Ground

Due to the importance of sleep time minimisation, timely action and prioritisation of misfire activities is essential, including, but not limited to:

- focusing all efforts on dealing with the misfire to minimise the time the product is in the ground beyond the authorised sleep time;
- minimising people in the affected area and setting up an exclusion zone;
- identifying and documenting the exact location of misfired hole(s) for digging out;
- implementing ongoing visual inspections of the area to observe any signs indicating an impending reactive ground event or an event in progress;
- consideration of the use of a thermal imaging camera to assist with identifying any heat released from the misfire area which may indicate a reactive ground event;
- re-firing of the misfired holes immediately if possible;
- excavation within the rated product sleep time.

Timely action is particularly critical if physical separation (i.e. liners) is used as there is a higher risk of uninhibited product coming into contact with potentially reactive surfaces. Limitations on sleep time for initiating systems must also be considered.

Standard misfire procedures are applicable unless explosive exposure time is likely to go beyond the recommended sleep times. Additions to standard misfire procedures would include:



- where re-firing is not possible, the product should be removed from the holes with a vacuum truck. The recovered product can be diluted with water; dumped from the vacuum truck in a known non-reactive area where possible; or decanted into appropriate vented storage for disposal;
- if use of a vacuum truck is not possible, then washing out could be considered. If washing out is required, an inhibited solution (i.e. 20% urea or Soda Ash solution) is preferred. If only water is available, copious amounts must be used.

11.3 Extending Sleep Time in Hot and/or Reactive Ground

During blasting operations, events may require the extending of sleep time beyond existing defined limits. Examples of this could include, misfires, on-bench floods, machine breakdown on bench, or electrical storm activity.

In the case of the misfire not being able to be removed within the authorised sleep time of the product the appropriate risk assessment procedures shall be followed. This shall include technical advice from the explosive supplier and shall consider the type of bulk product loaded (a higher emulsion content product will have more inhibitor and may offer a greater safety margin), and the type of zone risk (high versus medium). Prior to re-entry to extended sleep time zones, the management principles detailed in Section 12 of this Code should also be reviewed.

At all times the importance of minimising the time that the misfired product is in the ground must be emphasised and the number of people allowed to re-enter the blast area minimised.

Any authorisations to extend sleep time due to a misfire shall follow a risk assessment that takes the following information into consideration:

- length of sleep time tests performed – any reactions recorded?;
- the sleep time characteristics of the product, specifically taking into account any aspects relating to the emulsion/inhibitor level in the loaded product;
- the status of the ground temperature measured before loading, and how that compares with the standard test temperature of 55°C:
 - note that if temperature checks over several days are available (e.g. 3 readings over 3 days) and are increasing, then the initial temperature at the time of firing can be estimated by extrapolation;
 - if only one temperature check is available, and that is higher than either ambient temperature or the rest of shot, then measurement over time shall be continued to determine if the misfire area is rising above product limits before the time of firing;
- information on previous history of non-inhibited product performance in the reactive zone prior to discovery of reactive ground.



SECTION 12 Management of Premature Reaction/Detonation Events

Whilst the measures described in this Code are designed to minimize and mitigate the risks associated with blasting in reactive and/or elevated temperature ground, the possibility still exists that a premature reaction/detonation event may occur. This Section of the Code provides some guidelines to assist with the management of such an event.

In the first instance, it is critical that all personnel evacuate the area and the incident is reported immediately to senior site officials, the explosives provider, and the relevant statutory authorities.

Subsequent management of the event should take into consideration the following:

- setting up and maintaining an appropriate exclusion zone;
- identifying from a safe distance the detonated/fuming/reacting blast hole/s;
- constantly monitoring the complete loaded pattern and recording any unusual events and times these occur;
- prohibiting re-entry until any signs of chemical activity have completely ceased;
- establishing an agreed plan for tie-in and firing of the loaded portion of the blast pattern taking into consideration:
 - the need to minimise the number of personnel and their duration on the pattern;
 - an Emergency Plan (including evacuation) which all parties clearly understand;
 - ensuring all personnel have means of rapid egress from the blast pattern (and immediate area) at all times;
 - utilising a simple design to minimise the time to tie-in and to minimise opportunity for on-bench confusion.
- taking steps to tie-in and fire the pattern as soon as practicably and safely as possible;
- ensuring that, whilst ever there are personnel on the blast pattern, they are in radio contact with at least one observer located at a safe distance from the pattern. The observer must immediately advise by radio of any unusual observations and the pattern immediately evacuated;
- it is highly recommended that detonating cord NOT be used for surface tie-in;
- the tie-in sequence must take into consideration the location of the detonated/reacted hole/s. Initially it is recommended that a buffer be set up around these hole/s whilst the remainder of the pattern is tied-in. The buffer area should be tied in at the latest possible time before firing. Depending on reactivity level of the ground, affected holes may not be able to, or need to, be tied in. In case they are not tied in, refer to Section 11 of this Code;
- where signal tube based surface connectors are used, their tie-in should be sequenced in a manner that ensures the shot-firer is walking away from tied-in holes and thus can distance him/herself from possible multiple-hole initiation;
- video record the blast from a safe vantage point that allows a reasonable post-blast analysis for misfires;
- conduct a thorough post blast inspection of the muck-pile for potential misfired blast holes.



SECTION 13. Activity Sequence – Management Flowcharts

The following flowcharts are designed to show the logic in assessing a site which may have potentially elevated temperature and/or reactive ground conditions.

13.1 Identification and Analysis of the Risk of Reactivity at Green Field Sites

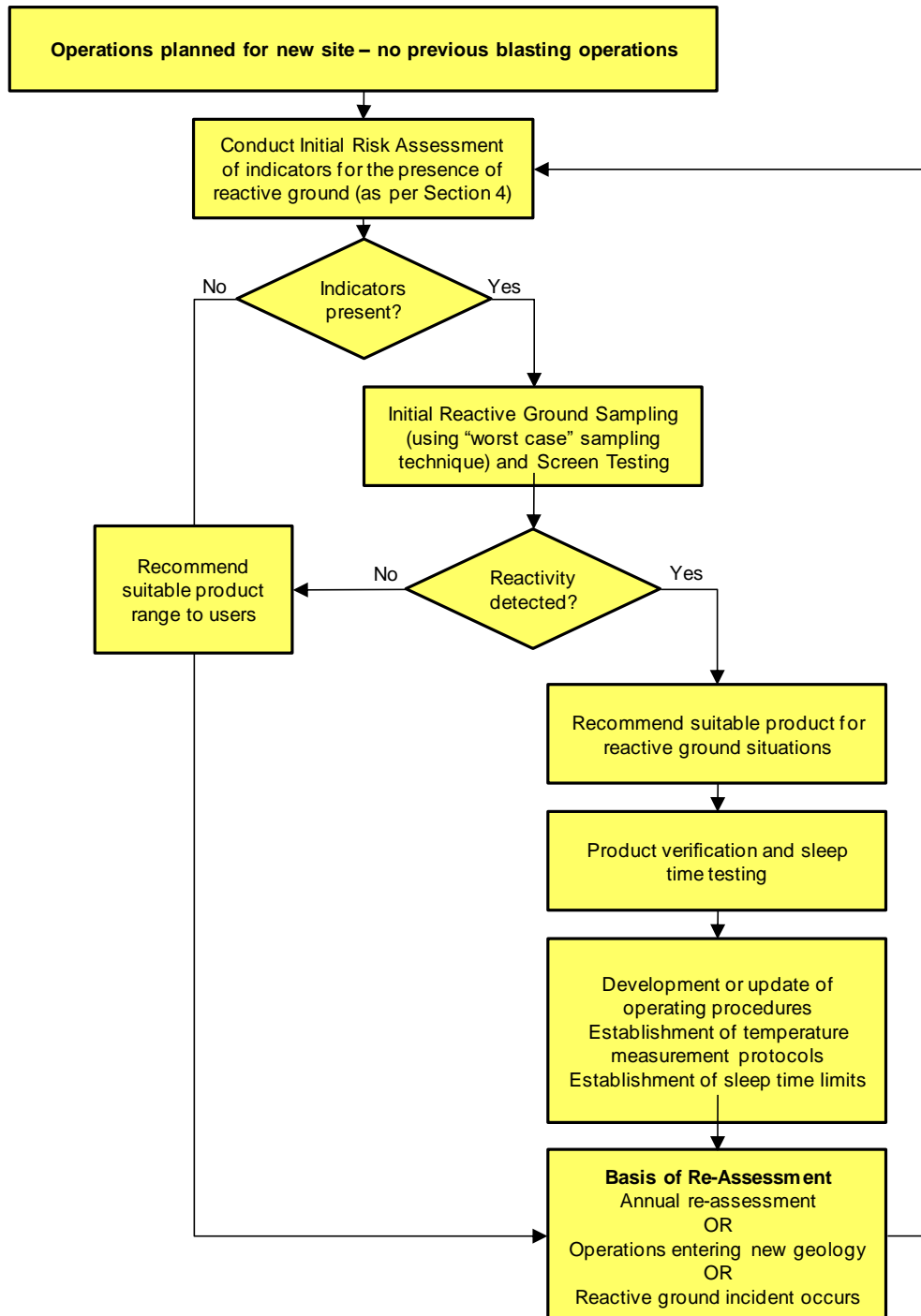



13.2 Identification and Analysis for the Risk of Reactivity at Existing Sites

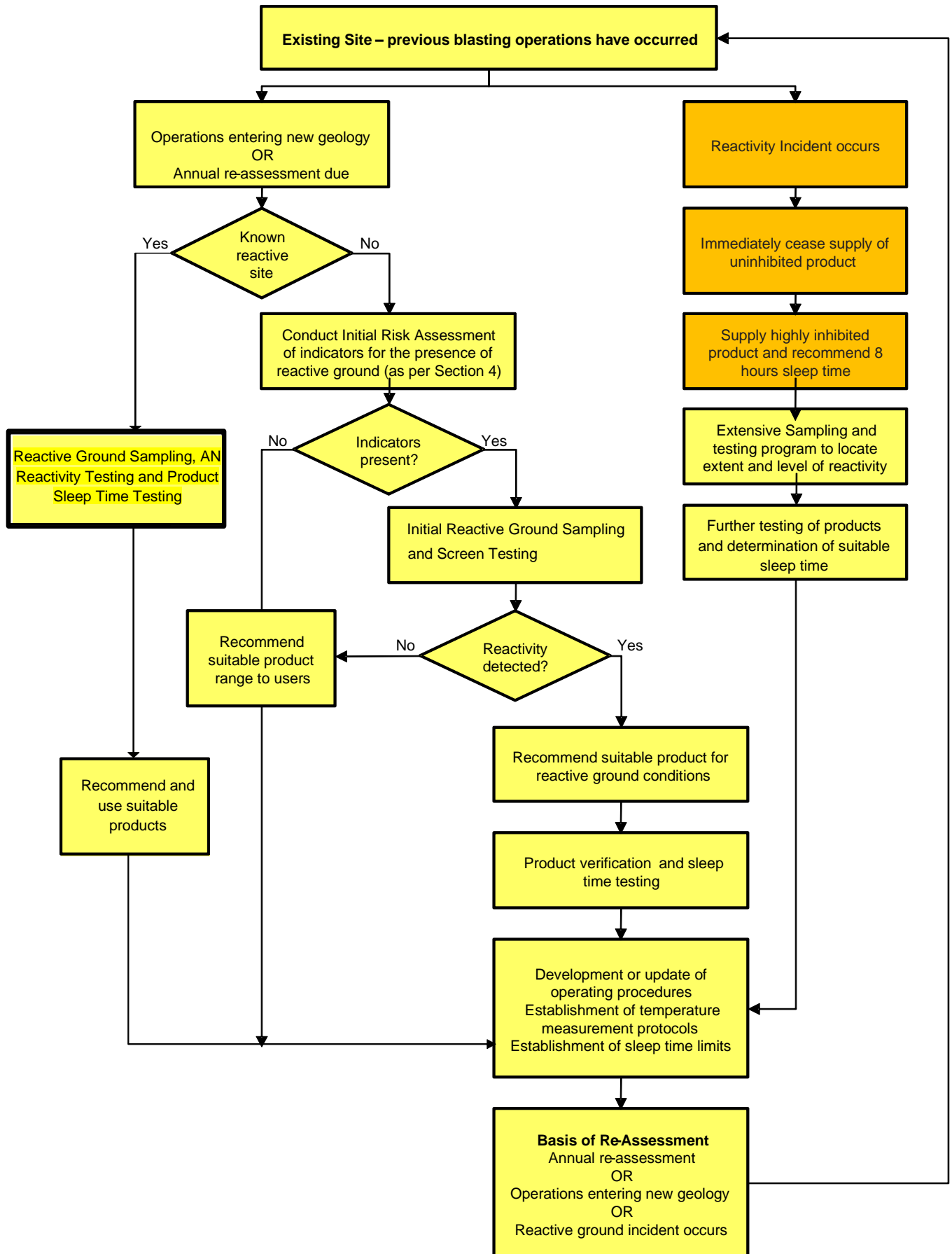



SECTION 14 Training

Based on this Code and other relevant documentation a comprehensive training package shall be developed for all involved in the handling and charging of explosives in elevated temperature and/or reactive ground conditions by the customer at each affected site. The training will ensure that each employee and contractor has a full and comprehensive understanding of:

- standard operating procedures developed for the handling and charging of explosives in elevated temperature and/or reactive ground conditions;
- site specific procedures;
- job responsibilities;
- hazards associated with the handling and charging of explosives in elevated temperature and/or reactive ground conditions;
- the use and ongoing maintenance of personal protective equipment (PPE). In some applications specialised PPE may be specified for the employee to use;
- emergency procedures especially where explosives exhibit any violent reaction during charging;
- identification of early warning signs of a potential incident.

All training will be documented and a process of verification and validation of competencies established. Revalidation of competency is to be carried out on a regular basis the frequency of which must be established on a site by site basis taking into consideration the site complexities of dealing with reactive and elevated temperature ground.



Appendices

Appendix 1 Typical Reactive Ground Indicator Risk Assessment Checklist

Indicators

Present (Y/N)

Are there any sulphides present?

Are black sulphide bearing sediments present?

Are sulphides within mineralised rock present?

Are any white or yellow salts present on the rock?.

Are there any acidic conditions as indicated by the colour of run-off water, usually yellow-red brown in colour?

Has there been significant corrosion of rock bolts, safety meshing and fixed equipment associated with the mining operation?

Has the spontaneous combustion of overburden or waste rock/ore either in dumps or in the pit occurred, especially as it is exposed to the air?

Is there an acrid smell of sulphur dioxide?

Have elevated blast hole temperatures been observed / recorded?

Have elevated ground temperatures been observed / recorded?

Appendix 2 Basis for the Isothermal Test Method in Determining Reactive Ground

The Isothermal test method was adopted to determine if a known rock sample had the potential for exothermic reaction with ammonium nitrate under controlled conditions; it was not designed to replicate the range of conditions encountered through the drill and blast process.

The chemistry of reactive ground (as shown in section 6.2) consists of numerous interdependent reactions occurring in pyritic ores, from the initial oxidative weathering of the pyrite through to the reactant and catalytic intermediates that form on contact with ammonium nitrate, ultimately forming the conditions required for exothermic decomposition of the ammonium nitrate explosive to occur.

The rate of the individual reactions (and heat generated) are variable for many reasons, including:

- the varying rates of oxidative weathering;
- concentration and surface area of sulphide present;
- varying levels and pH of moisture in the surrounding rock;
- the availability for reaction of ammonium nitrate component present;
- the structure and porosity of surrounding rock affecting localized entrapment of the reactants;
- any confinement makes gaseous intermediates available to further catalyze the AN/Sulfide reaction.

The physical conditions of the charged blasthole prevent heat dissipation due to variables including:

- poor thermal conductivity of pyritic ores and explosive products leading to localized heating;
- confinement prevents gaseous by-products from escaping the system resulting in higher pressure and temperature.

The parameters above are neither controllable nor easy to measure. The probability of the ideal conditions aligning such that an exothermic event occurs are unknown, hence an uncontrolled detonation is possible at any time.

It has been shown that laboratory scale tests must be conducted above a critical temperature (~50 degC) to reliably reproduce reactions observed in production blasting at ambient temperatures [Rumball, 1991; Tunaley, 1999; Kennedy and Tyson 2001]. This is because the safety and efficiency of the test method necessitates:

- small sample size;
- testing at ambient pressure so gaseous products of intermediate reactions can escape. Further, aluminum blocks have good thermal conductivity to allow control of test conditions.

Kinetic models, like the Frank-Kamenetskii equation, show how the varying physical conditions required for exothermic runaway directly affects the critical temperature of the reaction. Therefore, as the physical dimensions and thermal conductivity are scaled from the laboratory isothermal test to those approximating a production blast hole, the critical temperature is reduced significantly [Gunawan and Zhang, 2009], supporting previous work that showed the reactive ground hazard is present in ambient temperature ground [Rumball, 1991; Kenedy & Tyson, 2001; Littlefair et al, 2003].

Specific test conditions have been developed for the isothermal test method as follows:



Rock Milling

The rock is milled to <250µm to increase the homogeneity and surface area of the sample subjected to testing, so that any pyrite within the sample has an increased probability of exposure to the ammonium nitrate during testing.

Temperature of Testing

As defined in AS2187.2:2006, standard temperature ground is up to and including 55°C, and elevated temperature refers to material that is above 55°C. The test is performed at the minimum of 55°C±2°C (the highest standard temperature), or the highest temperature above 55°C to which the product will be exposed, to:

- (i) Increase the rate of reaction sufficiently to enable the induction phase to be completed in a relatively short time should the ground be reactive; and
- (ii) Increase the likelihood of a potential reaction being detected.

As the test is performed under isothermal conditions (i.e. the surroundings are at the same temperature as the reaction mixture), if the test temperature was sufficiently low, the rate of heat loss from the reacting test mixture to the surroundings may be sufficient to prevent a reaction being observed if it exceeds the rate of heat being generated. This limitation of the isothermal test was recognized by Rumball, who stated, “although the technique is capable of reproducing the aqueous initiation reactions, heat dissipation may prevent temperature increases which would otherwise catalyze further reaction”. For these reasons use of the isothermal test at temperatures below 55°C is not recommended as the risk of not accurately identifying reactive ground is likely. However, even though this is a limitation of the isothermal test method it is known that within the physical conditions of a blast hole the heat transfer characteristics are significantly different such that thermal runaway may readily occur. It is well documented that “the reaction of AN with sulfide minerals is an auto-catalyzed process, which after some induction time can lead to an exothermic decomposition even if the starting temperature of the mixture is around an ambient temperature of 25°C” (Briggs and Kelso 2002).

Classification of Reactivity

The isothermal test method classifies a sample as reactive if the test temperature shows an increase of greater than 2°C above background followed by a return to the background temperature. An exotherm of >2°C is considered significant based on measurement uncertainty of the K-type thermocouple used for temperature measurement.

Reactants

Chemically pure ammonium nitrate – The isothermal test method uses chemically pure ammonium nitrate to provide a standardised raw material for the test method. The variability in the type and amount of additives present in prilled ammonium nitrate are significant and may affect results in an unknown way. Hence, as per any standard test method, it is essential to minimise any potential for interference with the test results.

Weathering solution – The weathering solution used in the isothermal test method has been developed to specifically replicate the catalysts known to be generated in a concentrated form directly at the site of the pyrite and ammonium nitrate reaction. Tunaley, 1999 confirmed the ability of the catalysts mixture to



mimic weathering effects. When catalysts were added to freshly crushed samples the lowering of the onset temperature occurred. Once aged however, addition of extra catalyst made little difference to reactivity, presumably because sufficient catalytic species had already formed by natural oxidation. Within the small scale isothermal test method it is difficult to predict and replicate the rate at which the same build-up of catalysts would occur in any given blast hole. Hence, the use of the weathering solution provides a standardised method for comparing the reactivity of samples such that if a sample has the potential to react it will be identified within a reasonable and safe time frame.

Sampling

As per Section 7.3, the minimum recommended number of samples selected and collected for testing is 12. Depending on the outcome of the risk assessment and the geology and complexity of the site a greater number of samples may be selected. While the exact number of samples required to ensure all potentially reactive areas of a site have been tested may be difficult to determine, it is imperative that the samples actually selected for testing are selected by a geologist such that the samples most likely to react are used for testing. This selective testing is required to ensure the most highly reactive areas are assessed to ensure the reactive ground areas are accurately mapped and the appropriate inhibited products are used.

Test Duration

The ammonium nitrate screening test is performed for a duration of 7 days to ensure that if a sample has the potential to react within the conditions of the test this timeframe has shown to be a suitable duration

When testing inhibited product, four times the sleep time has been selected as the test duration required to provide a reasonable safety margin, primarily but not limited to the following;

- The exact amount and distribution of pyrite within any given blast hole is unknown hence sampling for reactive ground can never be conclusive that the most highly reactive samples have been found and sampled.
- The interactions between the pyrite and ammonium nitrate in any given blast hole cannot be accurately replicated due to; differing surface area interactions, thermal conductivity of both the rock and explosive, large scale of the reaction taking place.
- Due to the on-going weathering of the pyrite over time, the samples collected for testing may not have been at the highest state of reactivity.

Therefore, testing inhibited product for a minimum duration of four times the sleep time of the product enables the variables as above to be taken into consideration when understanding the potential reactivity of the site.

Appendix 3 Isothermal Reactive Ground Test.

This test is used to assess rock samples for exothermic reactivity with ammonium nitrate. The general aim of the test is to measure the induction time of the reaction at a constant temperature. The test conditions are not designed to mimic in-field conditions, but rather determine the chemical compatibility of the rock sample with ammonium nitrate. To that end, rock particle size, temperature, exposure time and the presence of by-products from oxidative weathering of the rock have all been optimized to assess the chemical compatibility as quickly as possible. This is to counter the fact that it is never known whether the most reactive ground on the site has been sampled and tested.

The test mixture consists of finely powdered rock, ammonium nitrate and a solution of ferrous and ferric sulphates.

The term 'isothermal' is used to indicate that rock is being tested in an environment with a constant and pre-determined background temperature. Exothermic events are signified by an experimentally significant increase in the temperature of the sample mixture beyond that of the background.

For normal temperature blasting applications at sites with either known or unknown reactivity, the background temperature to be used is $55^{\circ}\text{C}\pm 2^{\circ}\text{C}$ and the test is run for 7 days. The occurrence of an exothermic reaction at any time before that period terminates the test.

Where elevated ground temperature is evident, the same test is run but the test temperature is at least equal to the highest in-hole temperature, or at the maximum nominated temperature limit at the site. If the site changes its nominated maximum temperature then the isothermal testing must be repeated at this new temperature.

1. Equipment Required.

- Aluminium blocks – these are metal blocks with holes drilled to accommodate the glass tubes and distribute heat to the tubes evenly. In the example shown at the end of this section, the holes are 75mm deep with a 15mm radius rounded bottom, 30mm diameter. The blocks may also feature a shallow depression on the top to capture any overflow from vigorous reactions. Some variations in dimensions may occur, however in all cases the tubes shall be sized to ensure that samples sit below the top level of the heater block. The Aluminium blocks may be removable, or they may be permanently fixed into the heater block. An example of a typical aluminium block is shown on the following page.
- Ammonium nitrate – technical grade purity or better.
- Data logger – any data logger able to log temperatures at a rate of at least one data point per 30 seconds. It should be accompanied by a computer system to process the data.
- Dry block heater – an electrically heated tray able to heat the aluminium blocks uniformly at a heating rate of $0.6^{\circ}\text{C min}^{-1}$ or slower, and keep them at a pre-set temperature in the range $55^{\circ}\text{C} - 200^{\circ}\text{C}$ and to maintain that temperature to $\pm 2^{\circ}\text{C}$.
- Ferric sulphate – $\text{Fe}_2(\text{SO}_4)_3 \cdot 9\text{H}_2\text{O}$ technical grade or better.
- Ferrous sulphate – $\text{FeSO}_4 \cdot 7\text{H}_2\text{O}$ technical grade or better.
- Jaw crusher – Any crusher allowing fist-sized rocks to be broken into pieces of suitable size for the pulverising mill.
- Mixing apparatus – stainless steel spatula, glass or plastic mixing container.
- Pan balance – any electronic pan balance may be used provided it can weigh at least 300g to an accuracy of 0.05g or better.
- Protective clothing and equipment – safety glasses, rubber gloves, ear muffs or plugs, disposable dust mask and face visor.
- Pulverising mill – A mill with a capacity of 600 – 1000cc and capable of milling samples from the jaw crusher down to a sieve size of -250 micron within 60 seconds. A commercially available mill that meets these requirements is the Labtechnics LM1-P.

- Reaction vessels – glass centrifuge/digestion tubes capable of withstanding the reaction temperatures.
- Sample containers consisting of either – thermally sealable plastic vacuum bags able to hold at least 200g of powdered rock; or air tight plastic jars.
- Sieve – a stainless steel sieve with aperture size of 250 micron. The sieve should be inspected prior to use to ensure the mesh is not damaged.
- Thermocouples – k-type thermocouples with a manufacturing tolerance of $\pm 2.2^{\circ}\text{C}$.
- Tube seals consisting of either - rubber stoppers to fit into the glass tube with two 2mm diameter holes, one for a thermocouple probe, the other for pressure release; or aluminium foil to seal the tubes and reduce water loss from the reaction.
- Vacuum bag sealer – commercially available household vacuum bag sealers are suitable for this test.

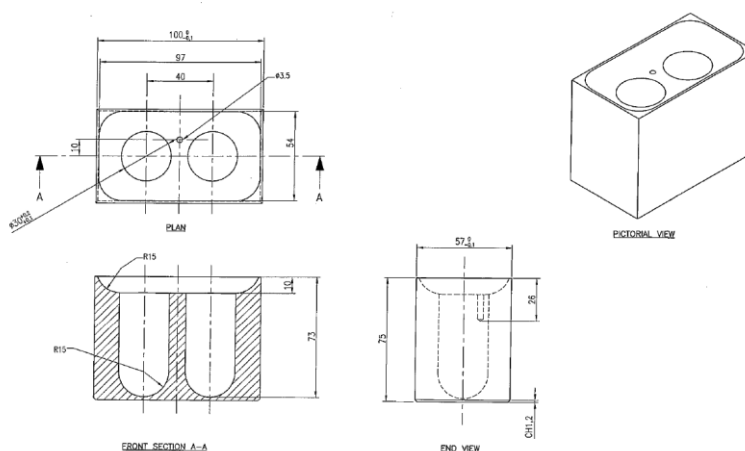

Example Drawing of Typical Aluminium Heater Blocks to fit a Thermoline Dry Block Heater

2. Equipment Checks

Thermocouples should be tested every two years against a certified reference thermometer, to ensure the thermocouples meet the manufacturer's specifications. ($\pm 2.2^{\circ}\text{C}$ for K-type thermocouples) Any non-conforming thermocouples should be discarded. Refer to NATA General Equipment – Calibration and Checks Table October 2015, www.nata.com.au.

It is also important to ensure the heating blocks are performing appropriately with no overrun above the set temperature on heating, with all test places within 2 degrees of the test temperature. These characteristics can be monitored during normal testing, and if any discrepancy is noted, the heating block should be repaired or replaced, and the testing repeated.

It is important to ensure no cross-contamination of samples occurs. The grinding equipment used has potential for this to occur and all grinding surfaces and other equipment that come into contact with samples must be thoroughly cleaned between each sample. It is recommended to test the processes on a two yearly basis or if the process is changed to ensure the procedure used is not causing cross-contamination. This may be done by crushing a known reactive sample followed by a known non-reactive sample and testing the non-reactive sample in the isothermal test. If any exotherm is found, contamination has occurred during the process.

It is recommended to perform "blanks" with inert material similar in particle size and heat capacity (e.g. sand) to milled rock, mixed with the ammonium nitrate/inhibited products and weathering solution and run the test. The resulting time-temperature trace may be compared with sample tests to determine if reactions occur during the heat up portion of the test, if the block has overrun its set point, or if heat has

transferred between adjacent tubes. These blanks should be repeated if the testing system changes, and if the blocks used are removable from the heater, or heat transfer between adjacent tubes is regularly observed. In these cases one or more blanks may need to be incorporated into each block of tubes tested.

3. Isothermal Test Method

The Isothermal Test Method is used for both AN Reactivity Screening and Product Selection Testing, with the difference between the two tests shown in steps 6 and 8.

STEP		KEY POINTS	SAFETY and QUALITY
1.	Rock crushing	<p>Check that the rock sample can fit into the jaw crusher. If required, use a hammer to break the whole rock into smaller pieces first.</p> <p>Ensure the collection tray for the crushed rock is clean, dry and in place.</p> <p>Feed rock into the crusher. Activate the crusher and allow enough time for all sample to be consumed. Collect a minimum of 200g of crushed rock.</p>	<p>Wear safety glasses, gloves, hearing protection and dust mask (also full face visor if using a hammer to break rock). Samples that contain heavy metals or other hazardous materials may require alternative PPE.</p> <p>Samples must not be oven dried at temperatures >50°C prior to testing as drying may cause premature air oxidation which may affect the reactivity of the sample.</p> <p>Where possible, only mill the minimum amount of rock needed for testing and unused samples shall be kept in rock form or crushed (vacuum sealed and stored in the freezer) to minimize oxidation.</p>
2.	Rock milling	<p>Ensure the internal surfaces of the mill are clean and dry.</p> <p>Load the mill with 200g of freshly crushed rock and mill for not more than 1 minute.</p>	<p>Mill for a minimum time to achieve 250 µm.</p> <p>A maximum milling time (≤ 60 sec) to minimise oxidation of sulphides shall be adopted.</p>
3.	Sieving	<p>Remove the powdered rock from the mill.</p> <p>Sieve a small portion of the sample using a 250-micron sieve to determine if the sample has been milled to <250 µm.</p>	<p>Sieving need only be performed once for a set of samples to ensure that the sample has been milled to 250µm. Discard the sieved portion as it has been exposed to oxidation.</p>
4.	Milled sample storage	<p>Store sample in vacuum sealed bag or airtight plastic container immediately after milling. Samples should be labelled with sample name, and date of milling.</p>	<p>The integrity of the vacuum and seal should be verified by visual inspection of the bags. Samples may also be stored under nitrogen.</p> <p>For storage periods greater than 48 hours the sealed bags/containers should be stored in a freezer.</p>

5.	Weathering by-products preparation	<table border="0" style="width: 100%; border-collapse: collapse;"> <thead> <tr> <th colspan="2" style="text-align: center;">Solution A</th> <th colspan="2" style="text-align: center;">Solution B</th> </tr> </thead> <tbody> <tr> <td style="text-align: center;">FeSO₄.7H₂O</td> <td style="text-align: center;">3.0 ± 0.1 g</td> <td style="text-align: center;">Fe₂(SO₄)₃.9H₂O</td> <td style="text-align: center;">6.9 ± 0.1 g</td> </tr> <tr> <td style="text-align: center;">H₂O</td> <td style="text-align: center;">22.0 ± 0.1 g</td> <td style="text-align: center;">H₂O</td> <td style="text-align: center;">18.1 ± 0.1 g</td> </tr> </tbody> </table> <p>Solutions A and B should then be mixed together producing 50g of 'weathering by-products solution'.</p>	Solution A		Solution B		FeSO ₄ .7H ₂ O	3.0 ± 0.1 g	Fe ₂ (SO ₄) ₃ .9H ₂ O	6.9 ± 0.1 g	H ₂ O	22.0 ± 0.1 g	H ₂ O	18.1 ± 0.1 g	<p>Wear safety glasses and gloves</p> <p>This results in 50g of weathering solution, and may be scaled up as appropriate for the amount of testing performed on the day.</p> <p>The solution may be stored for approximately one week, however should be discarded if any change is observed such as a precipitate or change in colour.</p>
Solution A		Solution B													
FeSO ₄ .7H ₂ O	3.0 ± 0.1 g	Fe ₂ (SO ₄) ₃ .9H ₂ O	6.9 ± 0.1 g												
H ₂ O	22.0 ± 0.1 g	H ₂ O	18.1 ± 0.1 g												
6a.	Preparation of AN Reactivity Test mixture	<p>In a suitable sized container, combine;</p> <p>18.0 ± 0.2 g of milled rock sample,</p> <p>18.0 ± 0.2 g of ammonium nitrate,</p> <p>4 ± 0.1 g of weathering by- products solution.</p> <p>Mix the contents with a spatula and immediately transfer the mixture to the glass reaction vessel. Weighing of materials and mixing can occur directly into the reaction vessel if it is large enough.</p> <p>Insert a 2-holed rubber stopper into the glass vessel, or seal with aluminium foil.</p>	<p>The rock samples or AN may be pre-weighed out for the set of samples to increase efficiency, however each reaction tube should then be completed (other reagents added and mixed) one at a time and transferred to a fume hood as soon as it is complete to reduce the risk of NO_x exposure. In rare cases the mixture will start producing NO_x immediately on mixing.</p>												
6b.	Preparation of Product Selection Test mixture	<p>In a suitable sized container, combine;</p> <p>18.0 ± 0.2 g of milled rock sample,</p> <p>18.0 ± 0.2 g of inhibited product,</p> <p>4 ± 0.1 g of weathering by- products solution</p> <p>Mix the contents with a spatula and immediately transfer the mixture to the glass reaction vessel.</p> <p>Weighing of materials and mixing can occur directly into the reaction vessel if it is large enough.</p> <p>It is recommended that product selection testing is completed in duplicate.</p> <p>Insert a 2-holed rubber stopper into the glass vessel, or seal with aluminium foil.</p>	<p>The rock samples or product may be pre-weighed out for the set of samples to increase efficiency, however each reaction tube should then be completed (other reagents added and mixed) one at a time and transferred to a fume hood as soon as it is complete to reduce the risk of NO_x exposure. In rare cases the mixture will start producing NO_x immediately on mixing.</p> <p>If samples have not been vacuum sealed and haven't been stored in the freezer, then each reactive rock sample must undergo an AN reactivity test at the same time as product testing to confirm the sample reactivity under the test conditions and provide a positive control for the test.</p>												
7.	Test set-up	<p>Place the reaction vessel containing the test mixture into an aluminium block on the Dry Block Heater. The aluminium block shall be at ambient temperature at this stage of the test.</p> <p>Insert a thermocouple through the rubber stopper/foil such that it is fully immersed in the reaction mixture. If possible the tip of the thermocouple should sit in the</p>	<p>The Dry Block Heater is to be set up in a well ventilated fume cupboard.</p> <p>For standard blasting applications, use 55°C.</p> <p>For testing related to ground at elevated temperatures, the test should be run at a temperature equal to or greater than the</p>												



		<p>test mixture approximately 1 cm from the bottom of the tube.</p> <p>Configure the data logger to log one data point at least every 30 seconds.</p> <p>Set the temperature of dry block heater to the target test temperature and set the heating rate such that the heater block doesn't overshoot the target temperature.</p>	<p>nominated loading temperature limit for the site /or delineated area.</p> <p>It is recommended that negative control samples are used (known non-reactive samples), to ensure test conditions are met.</p> <p>If the dry block heater is known to overshoot the set temperature the block may be set to the required test temperature and left to stabilise prior to preparation and addition of the test samples.</p>
8a.	AN Reactivity Screening Test	<p>Monitor and record the sample temperature for the test period using the data logger.</p> <p>The AN reactivity screening test for each sample should run for a duration of 7 days unless any of the following applies:</p> <ul style="list-style-type: none"> - if the sample reacts, then the testing can be terminated within the 7-day period for that sample. 	<p>Any visible signs of reaction such as; NO_x or other gas evolution, smoke, charring or bubbling, or colour change can be recorded.</p> <p>Ensure fume hood sash is not open while a reaction is occurring or is likely to occur.</p> <p>Movement of the thermocouple and/or frothing of the sample can also result in the hottest section of the reacting mixture not being measured.</p>
8b.	Product Selection Testing	<p>Monitor and record the sample temperature for the test period using the data logger.</p> <p>Product Selection and Sleep-time Testing is completed for a duration of 4 x the required sleep time to a maximum of 28 days (ie a sleep time of 7 days requires 28 days of testing).</p>	<p>If exceptionally long sleep times are required in specialised blasting applications, a detailed risk assessment should be conducted by the site operator and the explosives supplier.</p> <p>Any visible signs of reaction such as; NO_x or other gas evolution, smoke, charring or bubbling, or colour change can be recorded.</p> <p>Ensure fume hood sash is not open while a reaction is occurring or is likely to occur.</p> <p>Movement of the thermocouple and/or frothing of the sample can also result in the hottest section of the reacting mixture not being measured.</p>
9.	Retesting	<p>When retesting of a sample is required, an AN Reactivity Screening test should be performed to confirm the sample is reactive.</p>	<p>If testing shows the known reactive sample to be non-reactive, then a fresh sample should be milled.</p>

4. Interpretation of Results

An exotherm that qualifies a sample as 'reactive' in this test has the following characteristics:



- It is greater than, or equal to, 2°C above the background temperature in the temperature/time trace of that particular sample;
- It shows both a rise from, and a return to the background temperature when the reaction is completed;
- reactions may be accompanied by visible signs, such as bubbling, and/or the generation of brown nitrogen oxides.

To calculate the height of an exotherm that has occurred during the test, subtract the baseline test temperature from the maximum temperature recorded during the test. The baseline temperature may be calculated as the average temperature over the test period excluding the ramp and exotherm if the variation experienced is <1°C. If the baseline variation is 1-2°C the baseline test temperature may be calculated as an average temperature in the region of the potential exotherm, taking care to exclude any tail of the peak. This is to exclude artefacts such as physical movement of the thermocouple and variations in laboratory temperature. If the baseline variation is greater than 2°C the test may be repeated as small exotherms may be obscured.

If the temperature difference between the baseline and maximum temperature is equal to, or greater than 2°C, then the sample must be classified as reactive. If the temperature difference is 1-2°C, then the sample may be classified as marginal. Marginal results may be due to very low levels of sulphide, premature aerial oxidation of the sample or reactions other than sulphide oxidation (e.g. carbonates reacting with acid). It may be due to a reaction where the thermocouple has been dislodged due to the sample frothing and rising in the tube. In these cases the maximum temperature is often not measured by the thermocouple and a reaction is not detected. Marginal samples should be considered if no reactive samples have been classified in a pit. Further testing may then be conducted to reclassify the marginal samples as being either not reactive or reactive. Further testing may include;

- retesting existing samples;
- re-sampling the area of the mine;
- quantitative sulphide analysis. If there are no sulphides present, then the sample cannot be reactive.

The time vs temperature chart of each sample should be examined, as some samples may exhibit more than one exotherm during the test period. The first exotherm greater or equal to 2°C above the baseline temperature should be reported, alternatively, all exotherms may be reported. The initial portion of the test should also be examined to determine if the sample has reacted during the temperature ramp period of the test.

If a reaction occurs during the period that the sample is being heated to the isothermal set point, an exotherm is harder to distinguish. Nevertheless, a reaction may be indicated by physical signs such as bubbling and/or brown NO_x fumes, and/or a temperature rise that was faster than other (non-reacting) samples being analysed at the same time. A known non-reactive sample performed under the same conditions can be used to provide a baseline of the heating curve. The size of the exotherm is then taken from the extrapolated baseline to the sample trace at any point in time. The maximum difference in temperature should then be used to classify the reactivity of the sample.



Example of an Isothermal test where the exothermic reaction is evident during the temperature ramp up stage.-

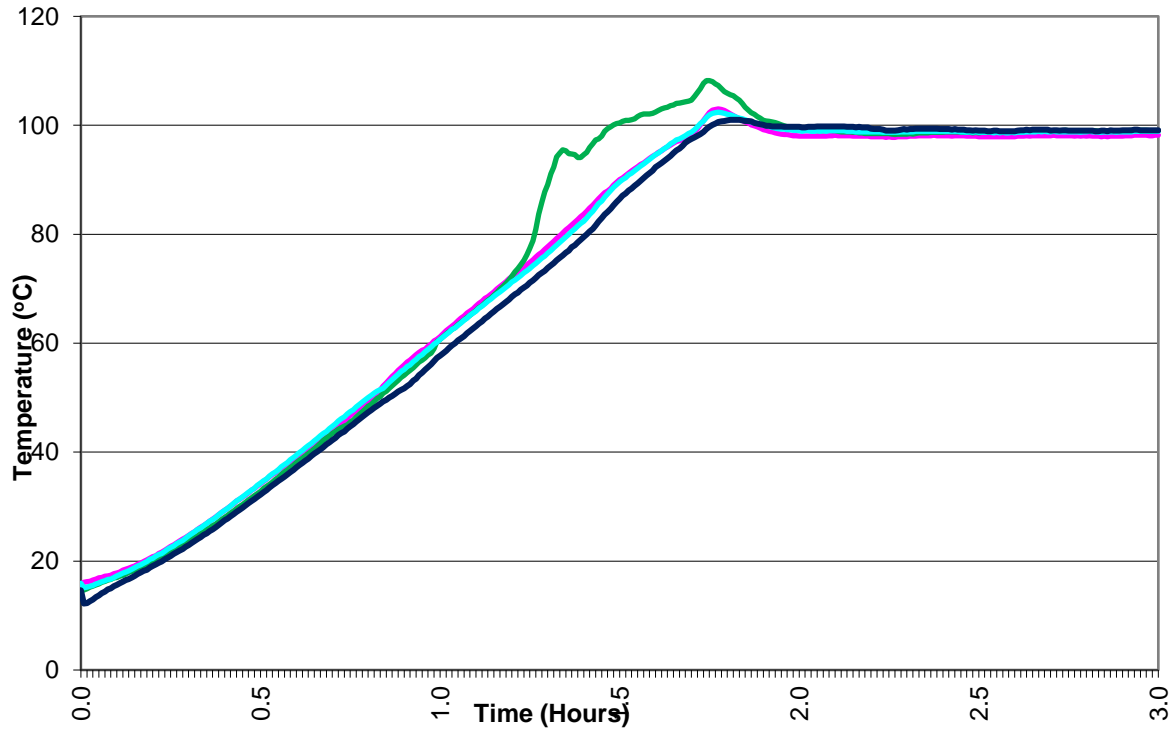

As indicated in the definitions section (Section 1.2), the “reactivity” of a sample or the ease at which a sulphide/nitrate reaction occurs is related to the induction time. Therefore, under the same test conditions, the period of time from the start of the test until an exotherm occurs is the induction time, and consequently enables a series of samples to be ranked as “most reactive” to “least reactive” with the “most reactive” sample reacting first. The “intensity” of a reaction is related to the size of the exotherm and does not relate to the induction time.

The reactivity of stored samples can change over time due to oxidation and/or changes in moisture content. Hence, when completing re-tests, if the reactivity of a sample has changed significantly than fresh samples shall be milled and tested (if available).



Appendix 4 Bucket Test for Reactive Ground

The Bucket Test is designed as a large-scale test to provide on-site reactivity data in addition to the laboratory isothermal testing. The test is carried out by mixing equal weights of explosive and crushed ground in a 20 litre plastic bucket and examining the contents on a regular basis to detect whether or not a reaction has occurred.

The test may be affected by the prevailing ambient conditions at the time the test is carried out and this may need to be taken into consideration when interpreting the outcomes of the test.

The bucket and its contents must be placed in a remote location and access to the site restricted to within 100m as, for safety reason, it must be assumed that a violent reaction and detonation may occur during the test. Where multiple tests are being carried out buckets must be separated by at least 5m.

1. Test Method

The test method is outlined below.

1. The selected ground sample is crushed to 5mm particle size in a jaw crusher, then to sub-2mm particle size in a roll crusher. 2kg of crushed ground is required.
2. 1kg of ground is placed in a 20 litre plastic bucket. 54 millilitres of water is added and thoroughly mixed into the ground with a flat stake. The amount of water added at this stage is half the total amount required for the test. The total amount of water used is 5.4% w/w based on the ground mass (i.e. 108ml of water).
3. 2kg of the explosive to be tested is added evenly on top of the ground.
4. The remaining 1kg of ground and 54ml of water is added and thoroughly mixed in with a flat stake until a homogenous mixture is achieved.
5. Breather holes are placed through the side of the bucket and the lid placed on the bucket to protect the contents from the weather.
6. The bucket is inspected on a regular basis to determine whether any reaction between the explosive and the ground has occurred. Inspection should be carried out at six regular intervals in the first 24 hrs; then three times per day for the remainder of the first week; and thereafter twice daily until the test is concluded.

2. Precautions

The buckets and their contents must be placed in a remote location with access restricted to within 100m. If there are any signs of reaction, as indicated by the evolution of gases/fumes, the site must not be entered, but must be immediately evacuated until at least two hours after all signs of reaction have ceased.

The generation of orange coloured fumes indicates that a violent reaction is underway and evacuation from the site must be immediate.

When inspecting buckets, it is recommended that this be carried out by two people – one carrying out the inspection of the buckets and the other as an observer watching for the start of any reaction. Unless adequate lighting is available at the site all inspections should be carried out in day-light hours.

3. Interpretation of Results

A reaction between the explosive and the ground is deemed to have taken place if:

- there are obvious signs that an explosion has occurred;
- the bucket has melted or caught fire;



- evidence of charring and discoloration within the contents of the bucket;
- any signs of the generation of fumes and/or steam from the bucket.

It is recommended that the test be carried out in triplicate for each ground sample. Generally, the test is carried out with ANFO over seven days as a first indication as to whether or not the ground is reactive. Should a reaction occur in any of the triplicate samples the ground is deemed to be “reactive” and appropriate precautions as detailed in this Code must be adopted in charging blast holes on the site. If a decision is made to use an inhibited explosive then the test should be repeated on the selected inhibited explosive with those ground samples, which reacted with ANFO, over a period of at least 28 days. The bucket test does not replace the isothermal test for determining site reactivity, product selection, and/or sleep time. The bucket test provides supplementary site-specific information to complement isothermal test results.

Appendix 5 Sample Audit Guidelines for the Inspection of Laboratories

Below is an example audit guide for the inspection of laboratories conducting reactive ground isothermal testing using a dry-block heater.

Audits are to be conducted with reference to the complete Code of Practice. This guide is provided as an indication of some specific items to be checked for laboratory compliance; it is not intended to be a comprehensive checklist of requirements.

In addition, any other aspects of laboratory operation that relate to the integrity of reactive ground testing may be considered in order for the explosives supplier to be satisfied that the results provide a reliable indication of the potential for reactive ground.

Subject	Requirement	Compliant or Non Compliant	Comment
Equipment	Heating blocks are aluminium with drilled holes that are of sufficient depth to ensure that the correct mass of sample is held below the top level of the heater block.		
	Reagents are technical grade pure, or better. Ammonium nitrate, ferric sulphate, ferrous sulphate Deionised water is used for preparing weathering solution		
	Weathering solution is prepared correctly and is not stored for longer than 1 week		
	Data logger is capable of collecting at least one data point per 30 seconds		
	Pan balance calibration checks show balance is able to weigh at least 300g to ± 0.05 g or better. E.g. 300g check masses give results within 299.95g and 300.05g		
	Protective clothing is available and appropriate Safety glasses, rubber gloves, ear muffs or plugs, disposable dust mask and face visor.		
	Laboratory personnel are using the appropriate protective clothing		
	Sieve with aperture size 250 micron and is undamaged		



Sample treatment (note; milling and testing may be conducted at separate facilities)	Samples are milled for less than 60 seconds to minimise oxidation of the sample.		
	Samples are sealed immediately after milling.		
	Samples are initially tested within 8 hours of milling.		
	Samples are stored in vacuum sealed bags or in air-tight containers.		
	Samples are clearly identified with sample IDs, milling date, mine name etc.		
	Sample identification is traceable to customer reference.		
Sample storage	Milled samples that are stored for possible retesting are vacuum sealed and stored in a freezer.		
	Where retesting occurs, a reactivity test is performed to ensure the sample is still reactive.		
	Where the rescreening test shows a previously reactive sample has become non-reactive then a new sample is milled from retained rock and a confirmatory screening test is performed.		
Testing	Tests are performed in a fume hood to minimise the possible spread of fume. (Tubes are placed in fume hood as soon as practically possible after weighing each tube is complete)		
	Tests are performed at $55^{\circ} \pm 2^{\circ}\text{C}$ for sites with normal ground temperatures.		
	At sites where elevated temperatures have been identified ($>55^{\circ}\text{C}$), testing is performed at an adopted standard elevated temperature.		
	Controls used (positive or negative) which are appropriate for the experimental design. Positive Controls should be used for all samples not stored in vacuum sealed bags in the freezer.		
	Procedures are in place to ensure samples are not mixed up and there is no contamination between samples throughout the entire testing and reporting process.		
Records & calibration	Laboratory report clearly shows the time traces and test temperature.		



	<p>Thermocouples have been tested to be within manufacturing tolerance within 2 years. ($\pm 2.2^{\circ}\text{C}$ for k-type thermocouples)</p>		
	<p>Evidence is available to show that the heating units are able to maintain required temperatures to $\pm 2^{\circ}\text{C}$ variation.</p>		
	<p>Records are maintained and include:</p> <ul style="list-style-type: none"> • date of sample receipt; • date of milling; • date and details of screening tests; • date and details of retests or sleep time testing; • name of person performing the test; • observations. 		
Interpretation of Results	<p>Peak heights are compared against baseline temperature.</p>		
	<p>The observations of the person performing the test are considered when classifying samples as reactive or non-reactive.</p>		
	<p>Time to reaction is reported.</p>		

Appendix 6 Ground Temperature Testing

The ground temperature of a mine shall be monitored when there is any risk of elevated temperature. A site-specific procedure and risk assessment should be developed that considers: 1) the cause of elevated temperature, and 2) the history and location of elevated temperature across site. Specific consideration should be given to the risk of blast holes rising above acceptable temperature limits during sleep times and implementing appropriate controls to prevent this.

Surface methods (such as IR guns, and FLIR) may be used for rapid detection of elevated temperature holes, however due to the limitations of these devices, they are rarely appropriate as the only method of temperature testing on a site. Final temperature testing on a suspected elevated temperature hole should be conducted by an in-hole method, with equipment or procedures that allow for detection of a temperature gradient and/or maximum temperature when retracting the device out of the hole as the maximum temperature may not be at the base of the hole.

The site-specific procedure/s should specify:

- how to identify which holes to test, and when, and how often to test (e.g. test every hole, test every hole in a certain known hot area, test 24 hours apart to check for increasing temp);
- what equipment is to be used to test (e.g. for initial checks, final checks);
- what procedure is to be used for testing, including the calibration of equipment;
- site temperature cutoffs (e.g. 55°C, 70°C);
- record keeping procedures;
- how to act on the information, including reporting procedures, retesting, backfilling etc.;
- how elevated temperature holes are to be marked.

The manufacturer should be consulted to determine appropriate calibration methods and advise on appropriate procedures for use (i.e. read times, maximum path lengths, use under various conditions). If moving to a new model of temperature testing equipment, or to using a different method, the new equipment should be validated against the old method/equipment or industry best practice. A new risk assessment should be completed to ensure the new equipment or methods is not introducing any risks.

Some temperature testing methods available are discussed in the following Table.

Method	Use	Advantage	Disadvantage
Thermocouple	In-hole temperatures, temperature profiling of holes. Disposable thermocouple may be used to measure product/hole	Can be used in deep holes, also where dust/steam is present. Some models may be able to be used in wet holes.	Labour intensive. If the thermocouples are pulled out of the holes too fast the temperature reading may not accurately stabilize. Thermocouples are also difficult to insert into upholes, or development holes.



	temperatures during sleep times and are destroyed in blast.		
IR-Gun	Surface temperatures, Very short holes (~5m), Rapid detection of elevated temperature holes.	Quick, relatively cheap	Cannot be used in wet holes. Beam is affected by dust and steam. Beam spreads out so may only read partway downhole (the depth will be diameter dependent).
FLIR Camera (Forward Looking Infrared Camera)	Surface temperatures, short holes, rapid detection of elevated holes.	Quick, offers a picture, rather than one measurement of an IR-Gun, which means it is more likely that any hot spots will be picked up, various models available with different resolution.	Not an in-hole method, so may miss elevated temperatures at the base of deep holes. Steam, dust, rain and fog affect the quality of the image and the distance the camera can see. Only the surface temperature of wet holes can be measured.
Hot hole indicator cards – Irreversible colour indicators cards that are placed on dipping tape	Rapid downhole detection of elevated temperatures.	Efficient detection of elevated temperature holes while dipping. Cheap, can be used until they change colour. Can be used wet. Multiple indicator cards can be used on one dipping tape to measure the temperature at different depths simultaneously.	Colour change may not be noticed. Operators must allow enough time in-hole for sensor to change colour (approximately 10 seconds). The sensor may not change colour if the sensor is pulled out quickly.
In-hole Infrared Probe	In-hole temperatures, temperature profiling of holes.	Can be used in deep holes and to obtain a temperature profile of a hole.	Labour intensive. If the probe is pulled out of the hole too quickly, the temperature reading may not accurately stabilize. The probes are not suitable for wet or steaming



			holes, and may be affected by dust.
--	--	--	-------------------------------------

Appendix 7 AUDIT CHECKLIST FOR ELEVATED TEMPERATURE AND REACTIVE GROUND BLASTING

AEISG Code: Elevated Temperature and Reactive Ground	Date:
Site/ Project:	

Compliance Details:

AEISG Section	Relevant Requirements	Describe what is in place to demonstrate compliance	Complies? (Y/N/NA)
1 SCOPE			
This document is for the use of AEISG Member Companies to ensure that all practices relating to the handling and charging of explosive products in elevated temperature and/or reactive ground conditions conform to the requirements set out in the AEISG Code of Practice.			
2 DEFINITIONS			
Refer to definitions listed in Section 1.2 of the Code.			
3 GENERAL REQUIREMENTS			
3.1 Personal protective and special equipment	All specialised personal and special protective equipment is approved for the task.		
3.2 Competencies and training	A training package is in place for all personnel involved in the handling and use of explosive products in elevated temperature and/or reactive		

AEISG Section	Relevant Requirements	Describe what is in place to demonstrate compliance	Complies? (Y/N/NA)
	<p>ground conditions. Training ensures each employee and contractor understands:</p> <ul style="list-style-type: none"> • Relevant standard operating procedures; • Relevant site-specific procedures; • Job responsibilities; • Hazards associated with handling and use of explosives in elevated temperature and/or reactive ground conditions; • The use and ongoing maintenance of PPE; • Emergency procedures especially where explosives exhibit any violent reaction during charging; • Identification of early warning signs of a potential incident. 		
3.3 Documentation of training	All training is documented, and verification of competencies is established.		
4 RISK ASSESSMENT			
4.1 Risk Assessment	<p>A risk assessment checklist for the site has been carried out to identify if any of the following reactive ground indicators are present:</p> <ul style="list-style-type: none"> • The presence of sulphides; • The presence of black sulphide bearing sediments; 		

AEISG Section	Relevant Requirements	Describe what is in place to demonstrate compliance	Complies? (Y/N/NA)
	<ul style="list-style-type: none"> • Sulphides within mineralised rock; • The presence of white or yellow salts on rock; • Acidic conditions (may be indicated by the colour of run-off water, usually yellow-red-brown in colour); • Significant corrosion of rock bolts, safety meshing and fixed equipment; • Spontaneous combustion of overburden or waste rock/ore in dumps or in the pit, especially as it is exposed to air. <p>This is completed by the site geologist or other competent person.</p> <p>If any of the above indicators are present, the explosive supplier will be contacted to organise reactive ground testing.</p>		
4.2 Frequency of Risk Assessment	Additional risk assessments are undertaken when conditions change within the mine (e.g. when moving into a new area of blasting, new geology, etc.)		

AEISG Section	Relevant Requirements	Describe what is in place to demonstrate compliance	Complies? (Y/N/NA)
5 ELEVATED TEMPERATURE BLASTING (i.e. TEMPERATURES ABOVE 55°C)			
5.1 Risk Management	<p>Where a site has been identified as having elevated temperature ground or blast holes with elevated temperatures:</p> <p>Site specific risk assessments and operating procedures are in place including appropriate control measures for the handling and charging of explosive products in elevated temperature ground.</p>		
5.2 Change Management	<p>Documented change management procedures are in place to ensure all key stakeholders are formally notified of any intention to change procedures.</p>		
5.3 Health and Safety	<p>Procedures are in place to manage areas of elevated temperature ground which may lead to the following health and safety hazards:</p> <ul style="list-style-type: none"> • Scalding from steam or hot water; • Toxic gases such as hydrogen sulphide and carbon monoxide. <p>Where required, site specific procedures include guidelines for the following:</p> <ul style="list-style-type: none"> • Evacuation when sulphur dioxide reaches a critical limit; 		

AEISG Section	Relevant Requirements	Describe what is in place to demonstrate compliance	Complies? (Y/N/NA)
	<ul style="list-style-type: none"> • Personnel to wear appropriate gas monitoring equipment and breathing apparatus when necessary. 		
5.4 Sleep Time	The sleep time of products in elevated temperature ground is minimised to prevent unnecessary heating of products. References are made to the Technical Data Sheet for the explosive products used.		
5.5 Hole Temperature Monitoring	<p>A site-specific procedure for hole temperature monitoring is in place. The temperature logging procedure includes the following:</p> <ul style="list-style-type: none"> • Selection of a suitable measurement device; • Hole-by-hole logging; • Recording maximum hole temperature; • Frequency of measurement; • How to act on temperature information. 		
5.6 Hole Loading Sequence	Where possible, loading occurs near the initiation point first to allow the pattern to be quickly tied in and fired in the event of a change in conditions. Where practical, the hottest holes are loaded last.		
5.7 Delineation of Zones	Delineation of ground into elevated temperature and non-elevated temperature zones is managed		

AEISG Section	Relevant Requirements	Describe what is in place to demonstrate compliance	Complies? (Y/N/NA)
	using multiple hole-by-hole temperature measurements.		
5.8 Spillages	Procedures for minimising spillages of explosives are in place specifying spillages are cleaned up immediately and initiating systems do not come into contact with spilt explosives.		
5.9 Product Selection	Suitable bulk, packaged and initiating products have been selected for use in elevated temperature applications as per their Technical Data Sheets.		
6 REACTIVE GROUND BLASTING			
6.1 Reactivity Testing	If indicators have been observed based on the initial risk assessment checklist, appropriate rock samples are collected from site and ammonium nitrate reactivity testing has been completed (refer to section 7 and 8 for more detail).		
6.2 Risk Management	Site specific risk assessments and operating procedures are in place including appropriate control measures for the handling and charging of explosive products in reactive ground.		
6.3 Change Management	Documented control and change management procedures are in place to ensure all key stakeholders are formally notified of any intention to change procedures (including sleep time, product, blasting area, etc.)		

AEISG Section	Relevant Requirements	Describe what is in place to demonstrate compliance	Complies? (Y/N/NA)
6.4 Health and Safety	<p>Site specific procedures include guidelines for the following:</p> <ul style="list-style-type: none"> • Evacuation of the area when there are visual signs of reactivity e.g. smoking or fuming charged blast holes. 		
6.5 Sleep Time	<p>The sleep time of the product in reactive ground does not exceed the maximum sleep time determined by the explosive's supplier based on reactivity testing.</p>		
6.6 Hole Temperature Monitoring	<p>The requirement for monitoring of hole temperature (or not) is specified in site specific procedures. The temperature logging procedure:</p> <ul style="list-style-type: none"> • Specifies suitable methods for rapid detection of hot holes e.g. IR guns; and • Ensures that thermocouple measurements are utilised to monitor all identifiable hot holes and record the maximum hole temperature; • Indicates the frequency of measurement; • Outlines how to act on temperature information. <p>(Where it can be shown, through a reasonable measurement campaign, that any single blast hole temperature in reactive ground does not exceed those considered ambient, it may not be</p>		

AEISG Section	Relevant Requirements	Describe what is in place to demonstrate compliance	Complies? (Y/N/NA)
	necessary to monitor hole temperature until such a time when blasting has progressed into a new area.)		
6.7 Shot Design	Shots are designed to minimise the risk of hole dislocation during blasting. If decked shots are required in reactive ground areas, an additional risk assessment is completed to identify any additional risks. Consideration is given to plans to dig out misfires within the recommended sleep time of the product.		
6.8 Hole Loading Sequence	Where possible, loading occurs near the initiation point first (i.e. load in the sequence in which the blast will be fired) to allow the pattern to be quickly tied in and fired in the event of a change in conditions (e.g. signs of reaction).		
6.9 Stemming Material	Stemming is carried out with non-reactive materials and stemming with drill cuttings is avoided.		
6.10 Product Spillage	Procedures for minimising spillages of explosives are in place specifying spillages are cleaned up immediately and initiating systems do not come into contact with spilt explosives.		

AEISG Section	Relevant Requirements	Describe what is in place to demonstrate compliance	Complies? (Y/N/NA)
6.11 Overfilling of Holes	Procedures for dipping holes while loading are in place to avoid overloading holes. Overloaded holes are not washed out.		
6.12 Risk Assessment Frequency	<p>Risk assessment checklists are repeated when any of the following changes occur:</p> <ul style="list-style-type: none"> • Changes in geology – e.g. different levels of sulphides; • Change to different blast area. <p>Site specific procedures and risk assessments are reviewed when any of the following changes occur:</p> <ul style="list-style-type: none"> • Changes to blasting practices – e.g. sleep time requirements; • Changes in explosive product; • Changes in explosives provider; • Change in the reactivity test results. 		
6.13 Delineation	Appropriate buffer zones between reactive and non-reactive areas are established. Procedures for loading explosives into delineated areas are in place and include an emergency action plan in the event that uninhibited (or insufficiently inhibited) product is loaded into reactive ground. Products are easily identifiable to		

AEISG Section	Relevant Requirements	Describe what is in place to demonstrate compliance	Complies? (Y/N/NA)
	reduce the risk of loading uninhibited product into reactive ground.		
6.14 Product Selection	<p>Suitable explosive products are used in reactive ground applications as per their Technical Data Sheets and product reactivity testing is completed to establish appropriate product and sleep time.</p> <p>During loading “start-up” and “clean out”, product is loaded into non-reactive blast holes, manufactured into a bucket for later disposal as active stemming in non-reactive blast holes (in situations where this is not possible, the product is manufactured in an emulsion rich-state).</p>		
7 SAMPLING FOR REACTIVITY TESTING			
7.1 Sample Selection	Sampling of targets rocks containing sulphides is undertaken in order to identify the “worst case” reactive rock samples. The site geologists, or other competent person, is engaged to collect whole rock samples from known locations.		
7.2 Sample Handling	Reactivity sampling and testing occurs just prior to explosive supply commencing.		

AEISG Section	Relevant Requirements	Describe what is in place to demonstrate compliance	Complies? (Y/N/NA)
7.3 Sample Size	Sample size is appropriate for the testing that is to be carried out: minimum of 0.5kg with the maximum rock size approximately “fist-size” (i.e. 50mm diameter).		
7.4 Sample Identification	Records are kept of sample identifications, collection points and date of collection.		
7.5 Sample Packaging	Packaging clearly identifies a sample from a known location and is robust enough to prevent rupture (and potential mixing) of samples. Where it is not possible to collect whole rock samples (e.g. when only rock chips or drill cuttings are available), samples are taken immediately after drilling and stored in sealed plastic bags.		
7.6 Sampling for Initial Screening	The minimum number of samples selected and collected for testing is 12. Samples are collected from each region of the site and from each stratum within that region that contain sulphides.		
7.7 Sampling for Ongoing Testing	In sites that have shown no previous evidence of reactive ground although risk factors are present:		

AEISG Section	Relevant Requirements	Describe what is in place to demonstrate compliance	Complies? (Y/N/NA)
	<ul style="list-style-type: none"> • Ongoing testing occurs on a regular basis according to the risk profile of the site; In sites that have shown evidence of reactive ground: • An ongoing sampling program is established and includes in site operating procedures; • Retesting occurs every 12 months as a minimum. 		
8 REACTIVE GROUND TESTING AND PRODUCT SELECTION			
8.1 Reactive Ground Testing	<p>Reactive ground isothermal testing is conducted according to Appendix 3 of The Code:</p> <ul style="list-style-type: none"> • Rock samples are crushed to a fine powder; • The rock powder is mixed with chemically pure ammonium nitrate and a weathering by-product solution; • The mixture is heated to and kept at 55°C ± 2°C, (for non-elevated temperature ground sites); • For elevated temperature ground sites, the test is performed at a temperature no lower than the maximum nominated temperature for site; 		

AEISG Section	Relevant Requirements	Describe what is in place to demonstrate compliance	Complies? (Y/N/NA)
	<ul style="list-style-type: none"> • The mixture is monitored for any visual signs of a reaction and reactivity is identified by an increase in temperature (exotherm); • Samples that exhibit an exotherm of 2°C or more above the baseline are classified as reactive; • Reactive samples are retested against the intended explosive product to be used to establish suitability and an appropriate sleep time. 		
8.2 Testing Agencies	Reactive ground isothermal testing is carried out by explosive providers or independent laboratories with appropriate equipment and trained personnel.		
9 SELECTION OF ACCESSORIES			
9.1 Accessory Selection	Initiating explosives used in elevated temperature and/or reactive ground conditions are compatible with the high explosives they are to be used with and the environment in which they are to be used. Relevant technical data sheets are consulted, and the suitability of the initiating explosives discussed with the supplier.		

AEISG Section	Relevant Requirements	Describe what is in place to demonstrate compliance	Complies? (Y/N/NA)
10 PROCEDURES FOR MISFIRES AND EXTENDING SLEEP TIME			
10.1 Misfires in Elevated Temperature Ground	Site specific misfire procedures are in place detailing the hazards associated with elevated temperature ground.		
10.2 Misfires in Reactive Ground	Site specific misfire procedures are in place detailing the hazards associated with reactive ground including the importance of sleep time minimisation, timely action and prioritisation of misfire activities.		
10.3 Extending Sleep Time	Risk assessment procedures are in place to manage the case of a misfire not being able to be removed within the authorised sleep time of the product.		
11 MANAGEMENT OF PREMATURE REACTION/DETONATION EVENTS			
11.1 Emergency Plan	A site emergency plan is in place detailing the evacuation of the area and incident reporting to senior site officials, the explosives provider and the relevant state authorities.		

Areas of Non-conformance and Action Plan

Non-Conformance Number	Section Number	Action Plan	Action by	Due Date	Completion Date	Comments
1						
2						
3						
4						
5						
6						
7						
8						

Compliance check summary

The observed management of elevated temperature and/or reactive ground complies/does not comply with the AEISG Code of Practice – Elevated Temperature and Reactive Ground.

Name of assessor/s

Date.....

Signature/s

Date of next review

About AEISG

The Australasian Explosives Industry Safety Group (AEISG) is an incorporated association of Australasian explosives manufacturers and suppliers originally formed in 1994.

Since then, AEISG membership has grown substantially to include most of the Australasian explosives industry. A full list of all current member organisations can be found on the AEISG website, www.aeiscg.org.au

The goal of AEISG is to continuously improve the level of safety and security throughout our industry in the manufacture, transport, storage, handling and use of explosives and related materials.

One of the strategies adopted by AEISG in this regard is to identify areas where improved and consistent standards of operational safety and security need to be applied, and then develop appropriate codes that reflect industry best practice in these areas.

AEISG codes of practice are adopted by members for the benefit of their employees, their customers and the general community. In the interest of promoting safety and security, the codes are freely available on the AEISG website.

To keep abreast of technological advancements, industry progress and regulatory changes, AEISG Codes of Practice are subject to regular review and updated through the issue of amendments or revised editions as necessary. It is important that users ensure they are in possession of the latest edition and aware of any amendments. References to superseded versions should be updated accordingly.

Contact Details: info@aeiscg.org.au

AEISG COP ELEVATED TEMPERATURE
AND REACTIVE GROUND

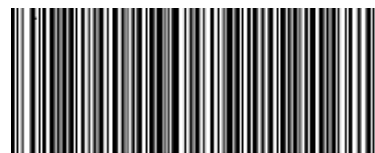

978-1-921308-27-7

Edition 5 April 2020